



APEX LB 120

    /illusioncad

DESIGNED FOR CANADA 

IIUSION
UNIVERSE

 www.illusionuniverse.ca

CONTENTS

1.Safety Instructions.....	1
2.Technical Specifications.....	2
3.DMX 512 Connection.....	3
4.Fixtures Installation.....	4
5.Control Panel.....	5
6.DMX Channels.....	11
7.Trobleshooting.....	15
8.Fixture Cleaning.....	16

1. Safety Instructions



WARNING

Please read the instruction carefully which includes important information about the installation, usage and maintenance.

Please keep this User Guide for future consultation. If you sell the unit to another user, be sure that they also receive this instruction manual.

Important:

Damages caused by the disregard of this user manual are not subject to warranty. The dealer will not accept liability for any resulting defects or problems.

- Unpack and check carefully to ensure that there is no transportation damage before using the unit.
- This product is suitable for wet locations. Do not immerse in water.
- DO install and operate by qualified operator.
- DO NOT allow children to operate the fixture.
- Use safety chain when fixing the unit. Handle the unit by carrying its base instead of head only.
- The unit must be installed in a location with adequate ventilation, at least 50cm from adjacent surfaces.
- Be sure that no ventilation slots are blocked, otherwise the unit will be overheated.
- Before operation, ensure that you are connecting this product to the proper voltage in accordance with the specifications in this manual or on the product's specification label.
- It's important to ground the yellow/green conductor to earth in order to avoid electric shock.
- Minimum ambient temperature TA: -10°C. Maximum ambient temperature TA: 40°C. Do not operate this product at a lower or higher temperature.
- DO NOT connect the device to any dimmer pack.
- During initial start-up some smoke or smell may arise. This is a normal process and does not necessarily mean that the device is defective, and it will decrease gradually within 15 minutes.
- Keep flammable materials away from the fixture while operating to avoid fire hazard.
- Make sure the power cord is not crimped or damaged; replace it immediately if damaged.
- Unit's surface temperature may reach up to 75°C. DO NOT touch the housing bare-handed during its operation.
- Avoid any flammable liquids, water or metal from entering the unit. Once it happens, cut off the mains power immediately.
- DO NOT operate in a dirty or dusty environment.
- DO clean the fixture regularly.
- DO NOT touch any wire during operation as there might be a hazard of electric shock.
- Avoid entanglement of the power cord with other wires.
- The minimum distance to objects/surface must be more than 24 meters.
- Replace fuse/lamp only with the same type.
- In the event of serious operating problems, stop using the unit immediately.
- Never turn on and off the unit time after time.
- The housing, the lenses, or the ultraviolet filter must be replaced if they are visibly damaged.
- DO NOT open the housing as there are no user serviceable parts inside.
- DO NOT attempt to operate this unit if it becomes damaged.
- DO NOT attempt any repairs yourself. Repairs carried out by unskilled people can lead to damage or malfunction. Please contact the nearest authorized technical assistance center if needed.
- Disconnect this product from its power source before servicing.

- DO use the original packaging if the device is to be transported.
- Turn off the power and allow approximately 15 minutes for the fixture to cool down before servicing.
- DO replace the bulb once it is damaged, deformed or life expired.
- Avoid direct eye exposure to the light source while the product is on.
- Never touch the bulb with bare fingers, as it may be hot.
- DO NOT operate this product if you see damage on the housing, shields, or cables. Have the damaged parts replaced by an authorized technician at once.

2. Technical Specifications

- Input Voltage: AC110-240V, 50/ 60Hz
- Light Source: 120W Laser Engine + 36pcs 0.5W RGB 3in1 LED
- Power Consumption: 160W
- Life Span: $\geq 20,000\text{H}$
- LEN Diameter: 126mm
- Beam Angle: 1.2°
- Color 1: 15 colors + Open
- Color 2: CMY Color Mixing
- Static Gobo: 29 static Gobos + Open
- Prism: 6-linear Prism and 8-facet Prism with bi-directional rotation at variable speed
- Focus: 0-100% Linear Focus
- Frost: 0-100% linear Frost
- Strobe: shutter speed adjustable from 1-25Hz
- LED Frequency: 600Hz-24,000Hz Adjustable
- Movement: 360° endless pan & tilt movement, 16 bit smooth and precise resolution for PAN/TILT movement
- Control Mode: DMX 512, Master/Slave, Work Auto, Sound Activated, Support RDM control
- DMX Channels: 33/41 DMX Channels
- DMX Connector: 3-PIN IP XLR IN/OUT
- Software update: Easy to update via DMX Connector
- Sleep mode: When disconnect DMX, the fixture returns to sleep mode automatically
- Body Structure: Aluminum Alloy Diecast + plastic
- Working Environment: $-20^\circ\text{C} \sim 45^\circ\text{C}$
- IP Rate: IP65 waterproof grade design
- Product Size: 280x268x429mm
- Packing Size: 545x375x380mm
- N.W: 16.95kgs / G.W: 18.90kgs

Dimension:

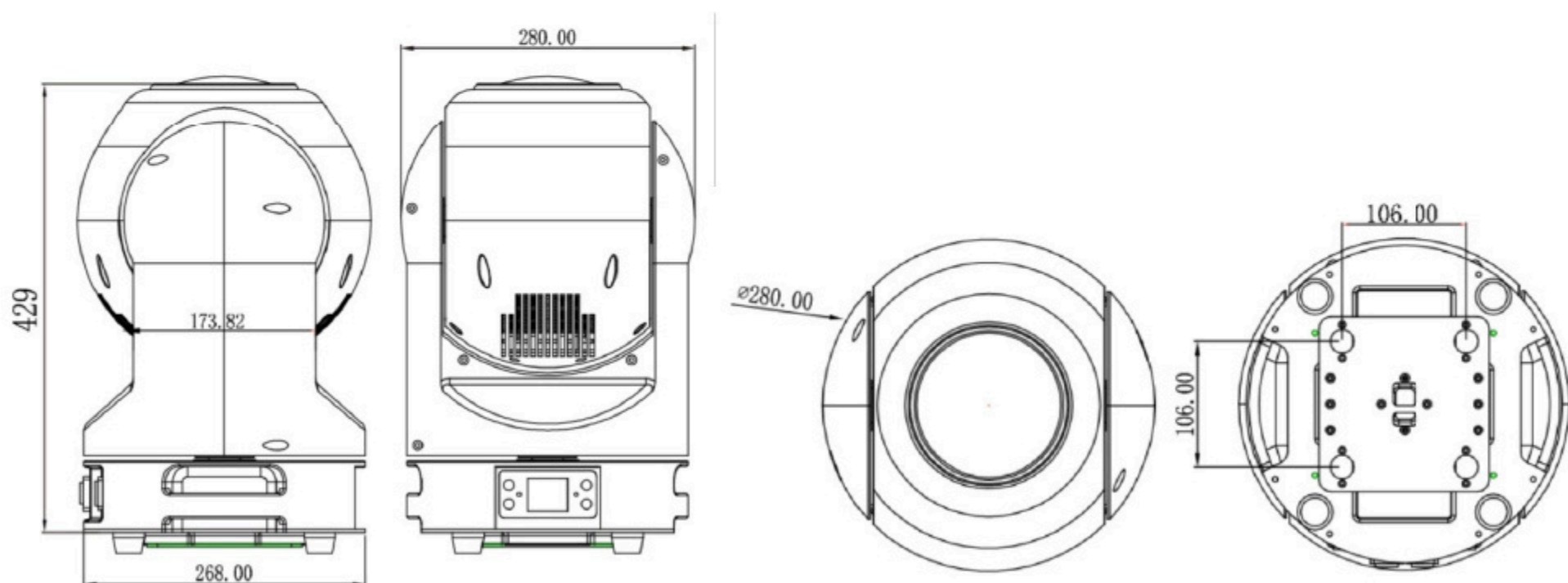

3. DMX 512 Connection

Light fixtures feature standard DMX input and output 3-core or 5-core XLR sockets. Use a twisted-pair signal cable shielded specifically for DMX 512; The signal line is generally connected at a distance of 150 meters, and the DMX512 signal amplifier must be added for long distance signal transmission.

Important: The wires should not touch each other or the metal housing.

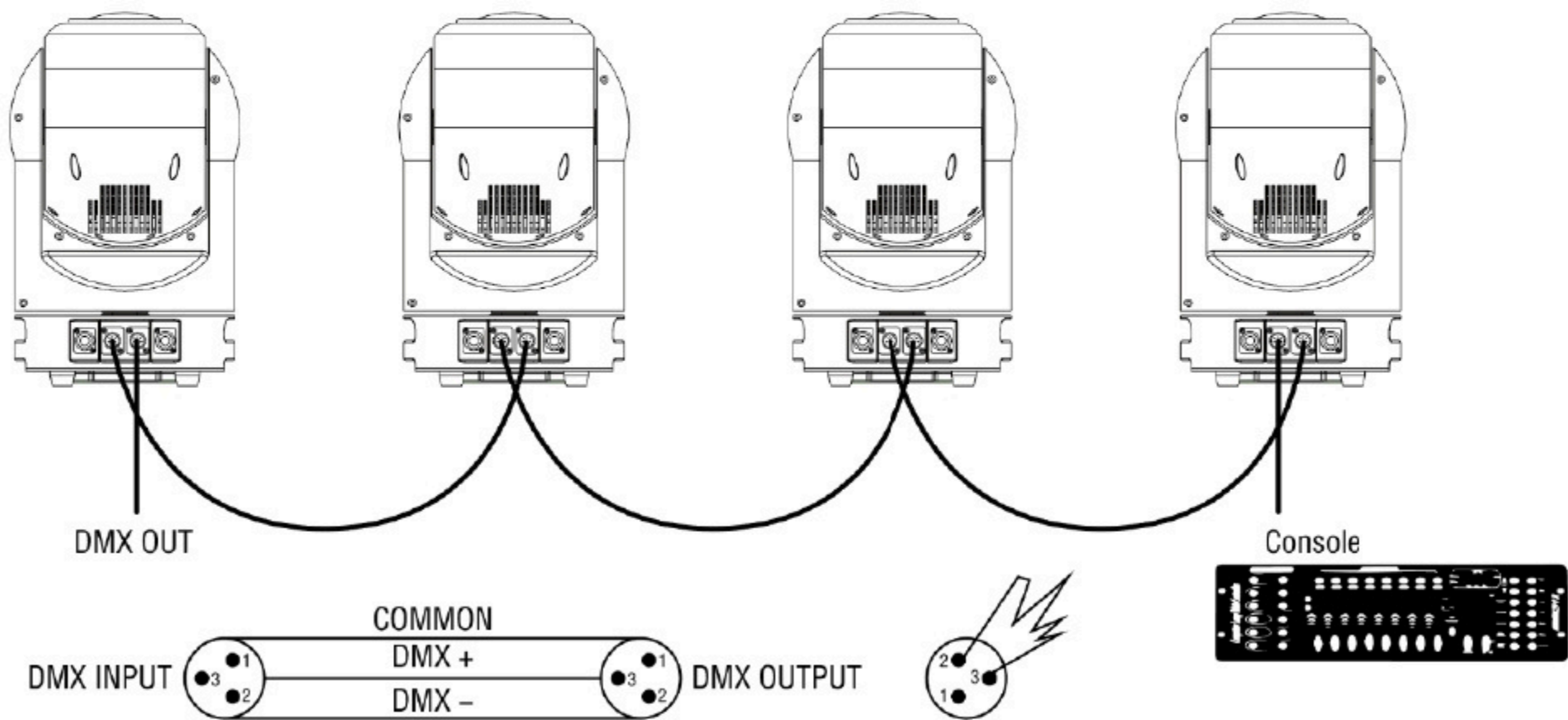
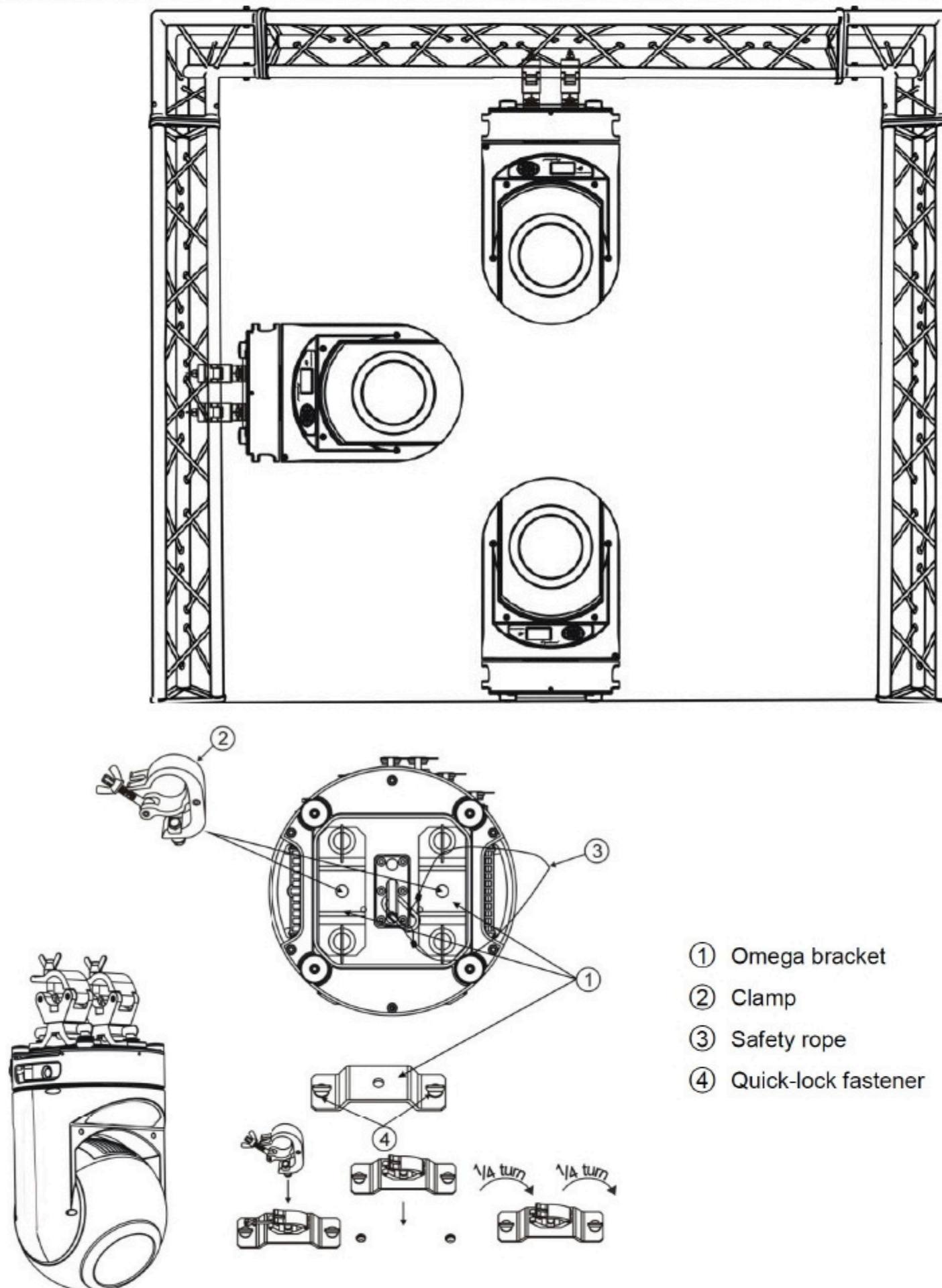

Figure 1 Schematic diagram of DMX signal wire connection

1. At last unit, the DMX cable has to be terminated with a terminator. Solder a 120-ohm 1/4W resistor between pin 2(DMX-) and pin 3(DMX+) into a 3-pin XLR-plug and plug it in the DMX-output of the last unit.
 2. Connect the unit together in a “daisy chain” by XLR plug cable from the output of the unit to the input of the next unit. The cable cannot be branched or split to a “Y” cable. DMX 512 is a very high-speed signal. Inadequate or damaged cables, soldered joints or corroded connectors can easily distort the signal and shut down the system.
 3. The DMX output and input connectors are pass-through to maintain the DMX circuit, when one of the units’ power is disconnected.
 4. Each lighting unit needs to have a DMX address to receive the data by the controller. The address number is between 1-512.
 5. The end of the DMX 512 system should be terminated to reduce signal errors.
 6. 3 pin XLR connectors are more popular than 5 pins XLR.
 - 3 pin XLR: Pin 1: GND, Pin 2: Negative signal (-), Pin 3: Positive signal (+)
 - 5 pin XLR: Pin 1: GND, Pin 2: Negative signal (-), Pin 3: Positive signal (+), Pin4, Pin5 not used.
- The calculation method of the starting address code of the lamp:
 The initial address code of the current luminaire is equal to (the initial address code of the previous luminaire)+(the number of channels of the luminaire)
- 1: The initial address code value of the first luminaire A001.
 - 2: The basic channel number of the controller should be greater than or equal to the total number of channels used by the luminaire.
 - 3: Note: when using any controller, each luminaire should have its own starting address code, if the first luminaire's starting address code is set A001, the number of luminaire channels is 16CH; Then the starting address code of the second lamp is set to A034; The starting address code of the third lamp is set to A067; And so on,(this setting also needs to be determined according to different consoles)

4. Fixture Installation

- DO install and operate by qualified operator. Fixture(s) should be installed in areas outside walking paths, seating areas, or away from areas where unauthorized personnel might reach the fixture by hand. NEVER stand directly below the fixture(s) when rigging, removing or servicing.
- Always ensure that the unit is firmly fixed to avoid vibration and slipping off during operation. Ensure that the trussing or area of installation must be able to hold 10 times the weight without any deformation. Always attach a safety cable that can hold at least 12 times the weight of the fixture whenever installing this fixture in a suspended environment to ensure that the fixture will not fall if the clamp fails.
- This fixture is fully operational in two different mounting positions: hanging upside-down or standing on the floor. We don't suggest to mount it sideways on trussing. Always use and install the supplied safety cable as a safety measure to prevent accidental damage and/or injury in the event the clamp fails.



Caution: For security reasons, you need to loop and wrap safety cables through fixture base handle and route and wrap through center bracket on fixture base (A). or pull the safety cables through the handle and around the truss (B).

The safety cable must be secured to keep from interfering with the pan and tile movement of the fixture.

Figure 2 Schematic diagram of the lamp hanging upside down1

5. Control panel

5.1 Key Instructions

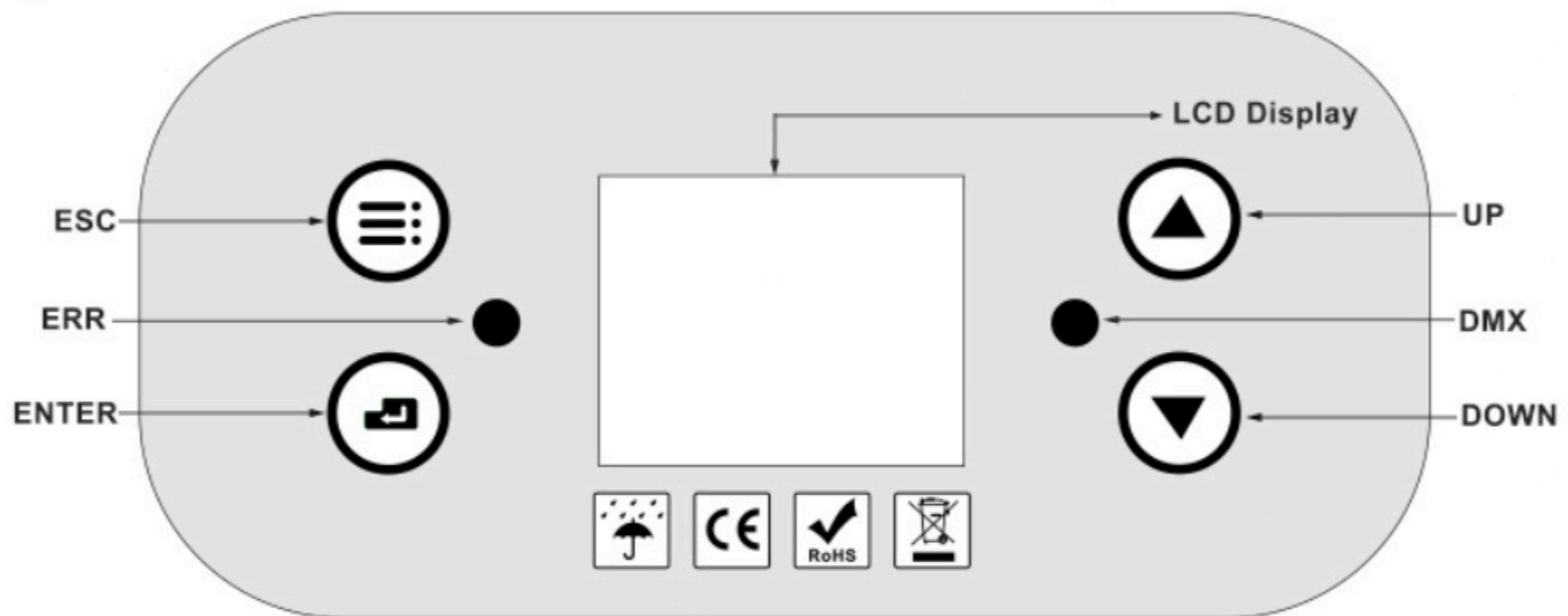

Figure 3 Schematic diagram of key description on the panel

● DMX	DMX Signal
● ERR	Error Signal
▲ UP	UP button
▼ DOWN	DOWN button
☰ ESC	Exit or Return button
📄 ENTER	Enter or Confirm the desired functions

- Turn on the unit, press the ESC button, enter the password UP-UP-DOWN-DOWN into menu mode
- Press the UP/DOWN button until the required function is shown on the monitor.
- Select the function by pressing the ENTER button.
- Use the UP/DOWN button to choose the submenu
- Press the ENTER button to store and automatically return to the last menu.
- Press the ESC button or let the unit idle 30 seconds to exit menu mode.
- The screen will be automatically locked if there is no operation for a long time, and can be unlocked by pressing the ESC button and enter the password again.

5.2 Menu Description



Figure 4 Schematic diagram of main menu

5.2.1 DMX Setup

Options	Instructions		
DMX Setup	DMX Address	001-512	DMX Address Setting (Press "Enter" to enter the editing state. press the "up" and "down" keys to change the address code. Press the "Enter" key again to select the Value. Press again to exit the editing state)
	Channel Mode	33CH	33 Channel Mode
		41CH	41 Channel Mode
	Run Mode	DMX	DMX Control Mode
		Auto	Work Auto by preset program
		Scene	Running by the preset Scene Program (01-12)

5.2.2 Personality

Options	Instructions		
Personality	Pan Inverse	Yes	Pan Invert Movement
		No	Keep the Pan clockwise movement
	Tilt Inverse	Yes	Tilt Invert Movement
		No	Keep the Tilt clockwise movement
	Tilt Feedback	On	Tilt Feedback ON
		Off	Tilt Feedback Off
	Dimmer Curve	Square law	Square Dimmer Curve setting
		Inv SQ Law	Inverse Square Dimmer Curve setting
		S-Curve	S-Curve Dimmer Curve Setting
		Linear	Linear Dimmer Curve Setting

	LED Frequency	600Hz	Press ▲ or ▼ to choose the desired Frequency, Press ↵ to confirm and Press ≡ to exit or return back to last menu
		1200Hz	
		2400Hz	
		4800Hz	
		9600Hz	
		12000Hz	
		24000Hz	
	No Data Mode	Hold	Continue running in its original state
		Blackout	Blackout and stop running
	M/S Mode	Slave	Slave Mode
Master		Master Mode	
Sensitivity	010-100	Sound Sensitivity setting	

5.2.3 Display

Options	Instructions		
Display	Display Rotate	Normal	Front display
		Rotate 180°	Screen inverted display
	Screen Lock	Off	Display screen always ON
		On	Display screen Lock after 3's without any operation
	Language	English	Set to English interface
		中文	Set to the Chinese interface

5.2.4 Motor Reset

Options	Instructions		
Motor Reset	All	Yes	All the Motors Reset
		No	Keep the preset setting
	Tilt	Yes	Tilt Motors Reset
		No	Keep the preset setting
	Effect	Yes	Effect Motors Reset
		No	Keep the preset setting

5.2.5 Manual control

This interface is used to control the current luminaire (does not receive DMX signals), corresponding to the channel. Refer to the channel table for details

Options	Instructions		
Manual Control	1.Pan	000-255	Press "OK" to enter the editing state. At this time, the hundreds digit is selected, and press the "up" and "down" keys to change the channel value. Press the "OK" key again to select the tens edit. Press "OK" again to select the ones edit. Press again to exit the
	2.PanFine	000-255	
	3.Tilt	000-255	
	4.TiltFine	000-255	
	5.PanTiltSpeed	000-255	

	6.Pan Rota	000-255	editing state
	7.Tilt Rota	000-255	
	8.Strobe	000-255	
	9.Dimmer	000-255	
	10.DimmerFine	000-255	
	11.Focus	000-255	
	12.FocusFine	000-255	
	13.Colour1	000-255	
	14.Colour1 Fine	000-255	
	15.Cyan	000-255	
	16.CyanFine	000-255	
	17.Magenta	000-255	
	18.MagentaFine	000-255	
	19.Yellow	000-255	
	20.YellowFine	000-255	
	21.Null	000-255	
	22.Null	000-255	
	23.Null	000-255	
	24.FixGobo	000-255	
	25.Prism	000-255	
	26.PrismRot	000-255	
	27.PrsimRot Fine	000-255	
	28.Prism2	000-255	
	29.Prism2Rot	000-255	
	30.Prism2Rot Fine	000-255	
	31.Frost	000-255	
	32.Null	000-255	
	33.Function	000-255	
	34.Led Dimmer	000-255	
	35.Led Strobe	000-255	
	36.Led Red	000-255	
	37.Led Green	000-255	
	38.Led Blue	000-255	
	39.Led Color Mac	000-255	
	40.Led Effect	000-255	
	41.Led Effect Spe	000-255	

5.2.6 Scene Editing

Options	Instructions			
		Scene State	Off	Scene Off
			On	Scene On
		Hold Time	001-255	Scene Time setting from 000-255
		1.Pan	000-255	Manual Control the DMX Channels, Press UP or

Scene Editing	Scene 1	2.PanFine	000-255	DOWN to choose the desire value from 000-255 ,Press Enter to confirm or Press Menu to exit
		3.Tilt	000-255	
		4.TiltFine	000-255	
		5.PanTiltSpeed	000-255	
		6.Pan Rota	000-255	
		7.Tilt Rota	000-255	
		8.Strobe	000-255	
		9.Dimmer	000-255	
		10.DimmerFine	000-255	
		11.Focus	000-255	
		12.FocusFine	000-255	
		13.Colour1	000-255	
		14.Colour1 Fine	000-255	
		15.Cyan	000-255	
		16.CyanFine	000-255	
		17.Magenta	000-255	
		18.MagentaFine	000-255	
		19.Yellow	000-255	
		20.YellowFine	000-255	
		21.Null	000-255	
		22.Null	000-255	
		23.Null	000-255	
		24.FixGobo	000-255	
		25.Prism	000-255	
		26.PrismRot	000-255	
		27.PrsimRot Fine	000-255	
		28.Prism2	000-255	
		29.Prism2Rot	000-255	
		30.Prism2Rot Fine	000-255	
		31.Frost	000-255	
		32.Null	000-255	
		33.Function	000-255	
		34.Led Dimmer	000-255	
		35.Led Strobe	000-255	
		36.Led Red	000-255	
		37.Led Green	000-255	
		38.Led Blue	000-255	
		39.Led Color Mac	000-255	
		40.Led Effect	000-255	
		41.Led Effect Spe	000-255	
		Scene 2	The same setting as scene1	
	Scene 3			
	Scene 4			
	Scene 5			
	Scene 6			

	Scene 7	
	Scene 8	
	Scene 9	
	Scene 10	
	Scene 11	
	Scene 12	

5.2.7 DMX Live

Options	Instructions		
DMX Live	1.Pan	xxx	Display the current DMX value
	2.PanFine	xxx	
	3.Tilt	xxx	
	4.TiltFine	xxx	
	5.PanTiltSpeed	xxx	
	6.Pan Rota	xxx	
	7.Tilt Rota	xxx	
	8.Strobe	xxx	
	9.Dimmer	xxx	
	10.DimmerFine	xxx	
	11.Focus	xxx	
	12.FocusFine	xxx	
	13.Colour1	xxx	
	14.Colour1 Fine	xxx	
	15.Cyan	xxx	
	16.CyanFine	xxx	
	17.Magenta	xxx	
	18.MagentaFine	xxx	
	19.Yellow	xxx	
	20.YellowFine	xxx	
	21.Null	xxx	
	22.Null	xxx	
	23.Null	xxx	
	24.FixGobo	xxx	
	25.Prism	xxx	
	26.PrismRot	xxx	
	27.PrsimRot Fine	xxx	
	28.Prism2	xxx	
	29.Prism2Rot	xxx	
	30.Prism2Rot Fine	xxx	
	31.Frost	xxx	
	32.Null	xxx	
	33.Function	xxx	
	34.Led Dimmer	xxx	
	35.Led Strobe	xxx	
	36.Led Red	xxx	

	37.Led Green	xxx	
	38.Led Blue	xxx	
	39.Led Color Mac	xxx	
	40.Led Effect	xxx	
	41.Led Effect Spe	xxx	

5.2.8 Service

Options	Instructions	
Service	Factory Setting	Only for Factory testing

5.2.9 Information

Options	Instructions	
Information	Power On Time	Record the cumulative bright-bubble time
	LED Hours	Record the lighting working time
	SW Version	1U:V1.02 2U:V.1.01 3U:V1.00
	RDM UID	0x07DB139C6AAA

6.DMX Channels

Channels		Function	Value	Description
41CH	33CH			
1	1	Pan	0-255	Pan Movement
2	2	Pan Fine	0-255	1.2° Pan fine Adjustment
3	3	Tilt	0-255	Tilt Movement
4	4	Tilt Fine	0-255	1.2° Tilt fine Adjustment
5	5	XY Speed	0-255	Pan/Tilt speed from fast to slow
6	6	Pan Rota	0-5	No Function
			6-130	Forward Pan Rotation from slow to fast
			131-255	Invert Pan Rotation from fast to slow
7	7	Tilt Rota	0-5	No Function
			6-130	Forward Tilt Rotation from slow to fast
			131-255	Invert Tilt Rotation from fast to slow
8	8	Strobe	0-9	Open
			10-199	Synchronous Strobe from slow to fast
			200-249	Random Strobe from show to fast
			250-255	Open
9	9	Dimmer	0-255	0-100% Linear Dimmer
10	10	Dimmer Fine	0-255	Dimmer Fine Adjustment
11	11	Focus	0-255	Focus from far to near
12	12	Focus Fine	0-255	Focus Fine Adjustment
13	13	Color Wheel	0-3	Open
			4-7	Open + Color 1
			8-11	Color 1

			12-15	Color 1 + Color 2
			16-19	Color 2
			20-23	Color 2 + Color 3
			24-27	Color 3
			28-31	Color 3 + Color 4
			32-35	Color 4
			36-39	Color 4 + Color 5
			40-43	Color 5
			44-47	Color 5 + Color 6
			48-51	Color 6
			52-55	Color 6 + Color 7
			56-59	Color 7
			60-63	Color 7 + Color 8
			64-67	Color 8
			68-71	Color 8 + Color 9
			72-75	Color 9
			76-79	Color 9 + Color 10
			80-83	Color 10
			84-87	Color 10 + Color 11
			88-91	Color 11
			92-95	Color 11 + Color 12
			96-99	Color 12
			100-103	Color 12 + Color 13
			104-107	Color 13
			108-111	Color 13 + Color 14
			112-115	Color 14
			116-119	Color 14 + Color 15
			120-123	Color 15
			124-127	Color 15 + Open
			128-191	Forward rotation from fast to slow
			192-255	Invert rotation from slow to fast
14	14	Colour Fine	0-255	Colour Fine Adjustment
15	15	Cyan	0-255	0-100% Cyan Dimmer
16	16	Cyan Fine	0-255	Cyan Color Fine Adjustment
17	17	Magenta	0-255	0-100% Magenta Dimmer
18	18	Magenta Fine	0-255	Magenta Color Fine Adjustment
19	19	Yellow	0-255	0-100% Yellow Dimmer
20	20	Yellow Fine	0-255	Yellow Color Fine Adjustment
21	21	None	0-255	No Function
22	22	None	0-255	No Function
23	23	None	0-255	No Function
24	24	Static Gobo	0-2	Open
			3-5	Gobo 1
			6-8	Gobo 2
			9-11	Gobo 3
			12-14	Gobo 4
			15-17	Gobo 5
			18-20	Gobo 6
			21-23	Gobo 7
			24-26	Gobo 8
			27-29	Gobo 9
			30-32	Gobo 10
			33-35	Gobo 11
			36-38	Gobo 12
39-41	Gobo 13			

			42-44	Gobo 14
			45-47	Gobo 15
			48-50	Color 16
			51-53	Gobo 17
			54-56	Gobo 18
			57-59	Gobo 19
			60-62	Gobo 20
			63-65	Gobo 21
			66-68	Gobo 22
			69-71	Gobo 23
			72-74	Gobo 24
			75-77	Gobo 25
			78-80	Gobo 26
			81-83	Gobo 27
			84-86	Gobo 28
			87-89	Gobo 29
			90-92	Open White Shake from Slow to Fast
			93-95	Gobo 1 Shake from Slow to Fast
			96-98	Gobo 2 Shake from Slow to Fast
			99-101	Gobo 3 Shake from Slow to Fast
			102-104	Gobo 4 Shake from Slow to Fast
			105-107	Gobo 5 Shake from Slow to Fast
			108-110	Gobo 6 Shake from Slow to Fast
			111-113	Gobo 7 Shake from Slow to Fast
			114-116	Gobo 8 Shake from Slow to Fast
			117-119	Gobo 9 Shake from Slow to Fast
			120-122	Gobo 10 Shake from Slow to Fast
			123-125	Gobo 11 Shake from Slow to Fast
			126-128	Gobo 12 Shake from Slow to Fast
			129-131	Gobo 13 Shake from Slow to Fast
			132-134	Gobo 14 Shake from Slow to Fast
			135-137	Gobo 15 Shake from Slow to Fast
			138-140	Gobo 16 Shake from Slow to Fast
			141-143	Gobo 17 Shake from Slow to Fast
			144-146	Gobo 18 Shake from Slow to Fast
			147-149	Gobo 19 Shake from Slow to Fast
			150-152	Gobo 20 Shake from Slow to Fast
			153-155	Gobo 21 Shake from Slow to Fast
			156-158	Gobo 22 Shake from Slow to Fast
			159-161	Gobo 23 Shake from Slow to Fast
			162-164	Gobo 24 Shake from Slow to Fast
			165-167	Gobo 25 Shake from Slow to Fast
			168-170	Gobo 26 Shake from Slow to Fast
			171-173	Gobo 27 Shake from Slow to Fast
			174-176	Gobo 28 Shake from Slow to Fast
			177-179	Gobo 29 Shake from Slow to Fast
			180-217	Forward rotation from fast to slow
			218-255	Invert rotation from slow to fast
25	25	Prism 1	0-127	No Function
			128-255	Prism 1 Insert
26	26	Prism 1 Rotation	0-127	Prism rotation to any position
			128-190	Forward rotation from fast to slow
			191-192	Stop
			193-255	Invert rotation from slow to fast

27	27	Prism 1 Rot Fine	0-255	Prism1 Rotation Fine adjustment
28	28	Prism 2	0-127	No Function
			128-255	Prism 2 Insert
29	29	Prism2 Rotation	0-127	Prism rotation to any position
			128-190	Forward rotation from fast to slow
			191-192	Stop
			193-255	Invert rotation from slow to fast
30	30	Prism 2 Rot Fine	0-255	Prism2 Rotation Fine adjustment
31	31	Frost	0-127	No Function
			128-255	Frost inserts
32	32	None		No function
33	33	Reset	0-249	No Function
			250-255	Reset All
34		LED Ring Dimmer	0-255	0-100% LED Ring Linear Dimmer
35		LED Ring Strobe	0-9	Closed
			10-199	Synchronous Strobe from slow to fast
			200-249	Random Strobe from slow to fast
			250-255	Open
36		LED Ring-Red	0-255	0-100% LED Ring-Red Dimmer
37		LED Ring-Green	0-255	0-100% LED Ring-Green Dimmer
38		LED Ring-Blue	0-255	0-100% LED Ring-Blue Dimmer
39		LED Macro Color	0-255	Macro Color for LED Ring
40		Preset Effect for LED	0-5	No Function
			6-10	Effect 1
			11-15	Effect 2
			16-20	Effect 3
			21-25	Effect 4
			26-30	Effect 5
			31-35	Effect 6
			36-40	Effect 7
			42-45	Effect 8
			46-50	Effect 9
			51-55	Effect 10
			56-60	Effect 11
			61-65	Effect 12
			66-70	Effect 13
			71-75	Effect 14
			76-80-	Effect 15
			81-85	Effect 16
			86-90	Effect 17
			91-95	Effect 18
			96-100	Effect 19
			101-105	Effect 20
			106-110	Effect 21
			111-115	Effect 22
			116-120	Effect 23
			121-125	Effect 24
			126-130	Effect 25
			131-135	Effect 26
			136-140	Effect 27
			141-145	Effect 28
			146-150	Effect 29
			151-155	Effect 30
			156-160	Effect 31
161-165	Effect 32			

			166-170	Effect 33
			171-175	Effect 34
			176-180	Effect 35
			181-185	Effect 36
			186-190	Effect 37
			191-195	Effect 38
			196-200	Effect 39
			201-205	Effect 40
			206-210	Effect 41
			211-215	Effect 42
			216-220	Effect 43
			221-225	Effect 44
			226-230	Effect 45
			231-235	Effect 46
			235-240	Effect 47
			241-245	Effect 48
			246-255	Effect 49
41		Speed for LED Preset Effect	0-255	Preset Effect Speed from slow to fast

7.Troubleshooting

Following are a few common problems that may occur during operation. Here are some suggestions for easy troubleshooting:

The light bulb is not working

- Check the voltage that matches the light fixture is installed;
- Check whether the lamp power supply connection or control switch is in poor contact;
- Check whether the power supply is insufficient;
- Check the DMX512 controller is sending instructions.

The light fixture does not accept control from the console after normal reset

- Check luminaire digital start address value and function options are correct;
- Check whether the connection of the communication control line is correct, the communication line is too long or has been interrupted;
- Check whether the control equipment is invalid, check whether the signal amplifier connected to the series is invalid;
- Check whether the communication line is too long or other devices interfere with each other;
- Optimize wiring, shorten the length of the control signal line, high-voltage and low-voltage lines separate wiring;
- Add signal amplifiers;
- Signal line adopts high quality shielded twisted pair wire;
- Connect the signal terminal resistor (120 ohms) at the end of the lamp.

Luminaire does not start

- Check that the power supply parameters are consistent with the luminaire;

- Check the lamps in the long distance transportation process due to extrusion deformation, internal parts vibration, moisture and other reasons, resulting in poor contact
Or fall off.
- Please check whether the internal wire integration connector of the lamp has fallen off and is loose.
- Check whether the electronic components of the lamp (such as electronic transformer, PCB board, motor control board, etc.) are loose, short circuit and burned out.

When working, the action of the X axis or Y axis of the luminaire is abnormal

- Check them one by one by following the previous step;
- Check whether the transmission belt corresponding to the X and Y axis direction in the lamp falls off and breaks;
- Check whether the data feedback receiver (optocoupler) corresponding to the X and Y directions in the lamp is damaged;
- Restart and reset once.

8. Fixture Cleaning

The cleaning of internal and external optical lenses and/or mirrors must be carried out periodically to optimize light output. Cleaning frequency depends on the environment in which the fixture operates: damp, smoky or particularly dirty surrounding can cause greater accumulation of dirt on the unit's optics.

- Clean with soft cloth and use normal glass to clean liquid.
- Always dry the parts carefully. □ Clean the external optics at least every 20 days.
- Clean the internal optics at least every 30 days.



Contact Us



SALES@ILLUSIONUNIVERSE.CA



UNIT 11, 10 FALCONER DRIVE,
MISSISSAUGA , ONTARIO, CANADA



WWW.ILLUSIONUNIVERSE.CA