



INNOVATING THE FUTURE OF ENTERTAINMENT TECHNOLOGY

**YOUR ALL-IN-ONE PARTNER FOR PROFESSIONAL LIGHTING,
VISUALS, FX, AND INFRASTRUCTURE**

ABOUT US

YOUR TRUSTED PARTNER IN PROFESSIONAL STAGE & VISUAL TECHNOLOGY

Founded with a vision to redefine how professionals experience light, sound, and visuals, Illusion Universe Co. Ltd. is a Canadian-based manufacturer and distributor of advanced stage lighting, LED video walls, trussing, FX systems, and infrastructure technology. We serve the growing needs of live production, rental and staging, theatre, clubs, houses of worship, broadcast, and AV installations across Canada and the United States. With a commitment to performance, reliability, and innovation, our product ecosystem is built for seamless integration, engineered for durability, and supported by a professional team with real-world expertise.

WHAT WE OFFER

- **Professional Lighting Systems:** Moving heads, theatre fixtures, architectural lights, strobes, washes, and follow spots.
- **LED Video Wall Solutions:** Indoor/outdoor panels, transparent screens, curved solutions, processors, touring frames.
- **Trussing & Rigging:** F34/F44 box trussing, baseplates, clamps, U-frames, corners, grids, boom arms.
- **Special Effects:** Fog, haze, CO₂ jets, cold spark machines, flame FX, confetti systems.
- **Control & Power Distribution:** DMX controllers, ArtNet nodes, dimmers, extenders, and power distros.
- **Cabling & Connectivity:** CSA/cETL-rated DMX, hybrid, and power cables for pro-use environments.
- **Crowd FX & Engagement Tools:** LED wristbands and synchronized RF-based audience engagement technologies.

OUR COMMITMENT

- **Engineered for Performance:** Built to meet CE, UL, CSA, and cETL standards.
- **Trusted by Professionals:** Across concert venues, theatres, clubs, and houses of worship.
- **Dealer & Integrator Support:** With B2B pricing, marketing assets, and training.
- **Canadian Logistics Hub:** Rapid fulfillment across North America from our Ontario HQ.
- **Tailored Solutions:** Custom systems, visualization, and on-site support available.

Corporate Headquarters

 Illusion Universe Co. Ltd.

 10 Falconer Dr Unit-11, Mississauga, Ontario L5N 3L8 , Canada

 sales@illusionuniverse.ca

 www.illusionuniverse.ca

CONTENT

01 Automated Movers

- Hybrid Moving Heads
- Beam Moving Heads
- Spot Moving Head
- Led Wash Moving Light

02 Static Wash Light

- Hex-IP
- Roar Shocker Panel Fix
- Pro Line 10 IP
- Pro Storm Bar 11
- Auora Batten 12 IP
- Flux F16
- Pixel Tube
- Vivid Series - 300W
- Vivid Series Shocker - 2
- T12 Washbar

03 Atmospheric

- Fog Machine
- Haze Machine
- Low Lying Fog
- Sparkular
- Jet Effects

04 Led Video Wall

- DWS Series
- M Series
- Smart Fast Fold Screen
- Flex Nova 15

05 Truss & More

- LD-12 BLK Truss
- Quick Stage
- Smart Stage
- Velvet Curtains
- Telescopic Cross-Bars
- GroundLift Max
- GroundLift Pro

06 Effects Light

- Prime 10000 RGB
- Prime MH 12W RGB
- Prime Laser X6
- Prime 40000 RGB

07 Booth Series

- Booth Smart DJ
- Booth Pro DJ

08 Cables & Accessories

- 3-Pin DMX Cables
- 5-Pin DMX Cables
- Stage Boxes & Snakes
- Multi-Channel Snakes
- PowerCon compatible
- True1 Compatible
- GAFF-X PRO Gaffer Tape

09 Controllers & Networking

- DMX Extender & ArtNet Node
- Data Stream M Pro
- DMX Splitter
- Data Stream M Truss

10 Deco Lights

- Video Bar 1000
- Video Bar Smart Controller
- Video Bar 360
- Flexible Neon Tube
- Neon Strip Light
- Video Pixel Rings

11 Audio

- SONICFORCE 150

AUTOMATED MOVERS



HYBRID MOVING HEADS

- ROBUST 200 HYBRID
- SHAFT 420 HYBRID
CMY
- ROBUST 350 HYBRID
CMY
- HYDREX BEAM 780



BEAM MOVING HEADS

- SHAFT 300 BEAM
- ROBUST 200 BEAM
- SHAFT 420 BEAM
- HYDREX BEAM
FORCE 420



SPOT MOVING HEAD

- RUMBLE M4 SPOT
- RUMBLE BEAM 360
- RUMBLE 4040 B-EYE
- RUMBLE SPOT WASH
360



LED MOVING LIGHT

- VISTA 1925 XR
- VISTA 740 MINI WASH
- COLORSHAFT FX-ONE
- COLORSHAFT CRYSTAL
- COLORSHAFT C12
- COLORSHAFT C9MH
WASH
- COLORSHAFT Z10
ZOOM BAR
- ROAR THUNDER
- ROAR STORM

ROBUST 200

HYBRID

HYBRID MOVING HEADS ROBUST 200 HYBRID

IIUSION
UNIVERSE



LIGHT SOURCE

- OSRAM 200W LED CHIP(21-24V,3A)
- Color temperature: 8000K
- Beam Angle: 3°-45°
- Diameter of optic lens: 97mm

FEATURES

- 0-100% 16BIT Smooth dimming with four dimming curves.
- Overheating self-energy protection can extending lamp life.
- Three phase Motor with SY Brand (XY axis magnetic coding positioning is more accurate.
- High quality LCD touch screen.
- Power in & Out connector, 3 or 5pin XLR in/out & output can optional.
- Folding clamp.
- **Housing material:** PA6 Nylon(Solid, high temperature resistance up to 200°, flame retardant)re updates.

FROST FILTER

- with smooth wash effect

FOCUS

- Electric focusing system

COLOR WHEEL

- Color Wheel : 7 Colors+open

GOBO WHEEL

- 8 static GOBOS + Open
- 7 Rotation GOBOS + Open

PRISM WHEELS

- 3-Fact prisms, Can be rotated in both directions
- Equipped with 8 PRISM and 8+16+24 Honeycomb Prism.

CONTROL

- Protocols: DMX512 & RDM
- Control Mode: DMX512 & Manual (On-board Controls)
- 1 DMX Channel Modes: 20 Channels
- 2.4-inch Color screen with touch buttons
- 0-100% Smooth Dimming
- Various strobe speeds
- With Wired Digital Communication Network

PAN/TILT

- Pan: 540 degrees (plus 16-bit fine pan)
- Tilt: 270 degrees (plus 16-bit fine tilt)
- 3 Phase, SY Brand (XY axis magnetic coding positioning is more accurate)

CONNECTIONS

- DMX Connections: 3-pin DMX In/Out (5 pin optional) (Data link max: 32 fixtures)
- Power Connections: Outdoor locking In/Out connections to daisy chain power

ELECTRICAL

- Multi-voltage operation: 100-240V, 50/60Hz
- Max power consumption: 220W

DIMENSIONS & WEIGHT

- Dimension: 13.3" (L) x 10" (W) x 20" (H) / 338 x 256 x 515mm
- Weight: 39.6 lbs. / 18 kg.

APPROVALS / RATINGS

- CE
- CSA Special Publication SPE-1000-21
- FCC

WHAT'S INCLUDED

- 2M, 14AWG power cord

COLOR WHEEL



FIXED GOBO



ROTATION GOBO



ILLUMINANCE

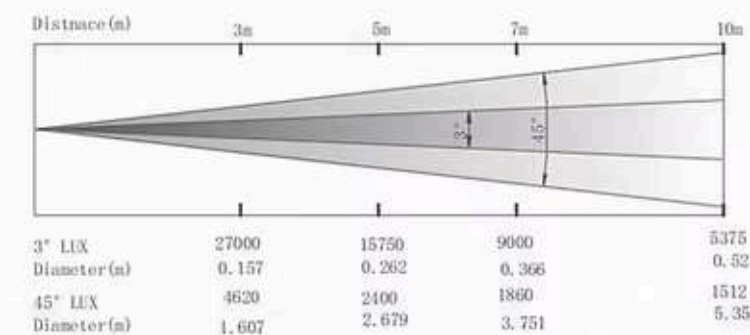

SIZE

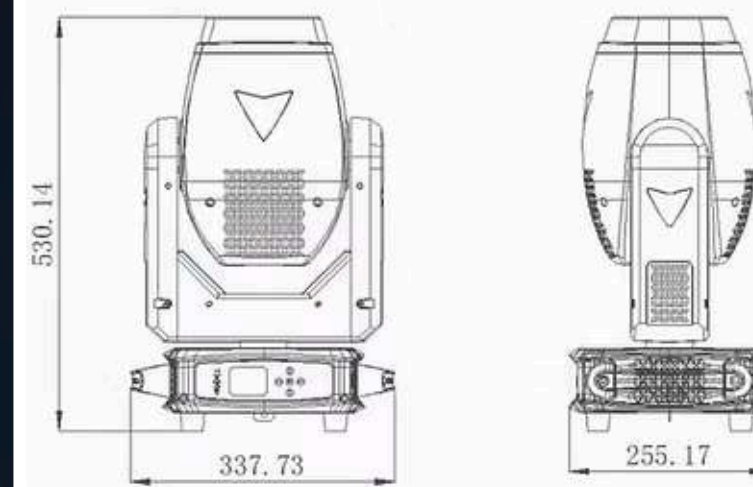

Scan the QR code for more product details

UPC# : 673324965029

SHAFT 420 HYBRID CMY

HYBRID MOVING HEADS SHAFT 420 HYBRID CMY



UPC# : 602835339357

LIGHT SOURCE

- Lamp Type: 1 x OSRAM SIRIUS HRI 420W
- RGB LEDs: (30+36+42) x 0.2W 3-IN-1 SMD LEDs
- Color Temperature: 7850K (±300K)
- CRI (Color Rendering Index): ≥ 83 (±5)
- Flicker-Free Operation: Optimized for TV and Film
- Lamp Life Span: Approx. 2500 hours (varies based on environmental conditions, voltage, usage patterns, and control settings)

OPTICAL SYSTEM

- Advanced Optics: High-resolution precision lenses
- Zoom Range:
- SPOT Mode: 4°-32°
- BEAM Mode: 2.5°
- Focus: Smooth and precise linear motorized focus

MOVEMENT

- PAN Movement:
 - Mode 1: 360° Continuous movement
 - Mode 2: 540° (8/16-bit)
- TILT Movement:
 - Mode 1: 360° Continuous movement
 - Mode 2: 270° (8/16-bit)
- Motors: High-speed, low-noise 3-phase motors
- Position Memory: Auto reposition after unexpected movement
- Reversible PAN/TILT

WASH SYSTEM

- Frost Filter: Linear soft frost effect for hybrid wash mode
- Smooth and even coverage

GOBO SYSTEM

- Rotating Gobo Wheel:
 - 8 rotatable and interchangeable glass gobos + open
 - Speed adjustable, stream effect, dithering effect
 - Rotatable clockwise/anti-clockwise
- Static Gobo Wheel:
 - 12 gobos + open
- Gobo Morphing: Dynamic overlays and transitions

COLOR SYSTEM

- Full CMY Color Mixing System
- 3 Color Wheels:
 - Each with 12 dichroic colors + open (half-color mode available)
- Rainbow Effect: Variable direction with speed adjustment
- 6-Color Effect Wheel

PRISM SYSTEM

- Dual Prism Wheels:
 - Prism 1: 4 different prisms (4-facet linear, 3-facet circular, 4-facet circular, 6-facet circular)
 - Prism 2: 4 different prisms (6-facet linear, 2-facet circular (6+12), 8-facet circular, 16-facet circular)
- Prism Indexing & Morphing: 16 types of morphing effects and 24 prism effects in total

COMPLIANCE & CERTIFICATIONS

- CE Certification
- LVD (2014/35/EU): Safety of electrical equipment supplied at low voltage
- EMC (2014/30/EU): Electromagnetic Compatibility
- RoHS (2011/65/EU): Restriction of hazardous substances
- CSA Special Publication SPE-1000-21

ENVIRONMENTAL CONDITIONS

- Operating Temperature: -25°C to 45°C
- IP Rating: IP20 (indoor use)

STROBE & DIMMING

- Strobe: 0-20Hz shutter/strobe with variable speed
- Effects: Preset variable/random strobe & dimming pulse
- Dimming: 0-100% smooth linear dimming

CONTROL & CONNECTIVITY

- DMX Channels: 33/38 channels (USITT DMX-512)
- Control Modes: DMX512, Master-Slave, Auto Mode
- RDM (Remote Device Management): Available
- Art-NET: Optional
- Wireless DMX Receiver: Built-in (Optional)
- Signal Protection: Shielded input for stable signal without interference
- Connectors:
 - DMX: 3-pin & 5-pin XLR IN/OUT
 - Network: RJ45 etherCON IN/OUT (optional with Art-Net)
- Software Update: Upgradable via DMX connectors (multi-unit daisy-chain update)

DISPLAY & INTERFACE

- Screen: 1.44" TFT LCD Display
- Control Buttons: 5-button navigation
- Screen Rotation: 180° reversible display
- Auto-Off: Display turns off when inactive
- Signal Indicator: DMX signal monitoring

COOLING SYSTEM

- Self-Adjusting Fan Cooling: Efficient low-noise operation
- Temperature Monitoring: Constant readout & management
- Over-Temperature Protection: Prevents overheating for long lifespan

HOUSING & BUILD QUALITY

- Material: Fireproof PA6 + fiber-reinforced plastic with aluminum & steel plates
- Handles: Dual side handles for easy handling

POWER SUPPLY

- Electronic Ballast: PT-SIRIUS 310W with Active PFC
- Voltage: AC100-240V, 50/60Hz
- Power Consumption: 630W
- Power: PowerCON IN/OUT with fuse protection

INSTALLATION & RIGGING

- Mounting Options:
 - Omega Clamps: 2x 1/4 turn fastening (vertical & horizontal adaptable)
- Safety Attachment Point: Available for secure rigging
- Operating Positions: Any (floor-mounted or truss-mounted)

ANIMATION SYSTEM

- Special Effects: Simulated dynamic flame, water effect, etc.



Scan the QR code for more product details

DIMENSIONS

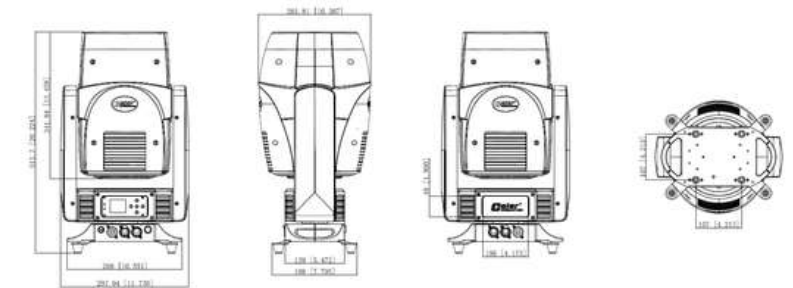

EFFECT

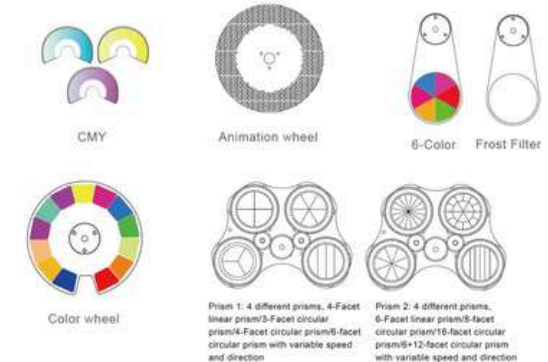

GOBO

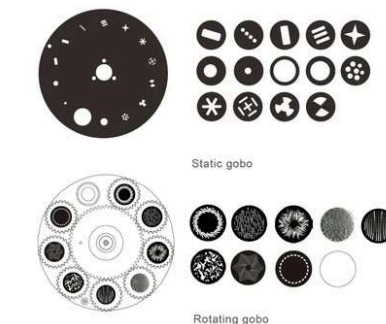

PHOTOMETRICS

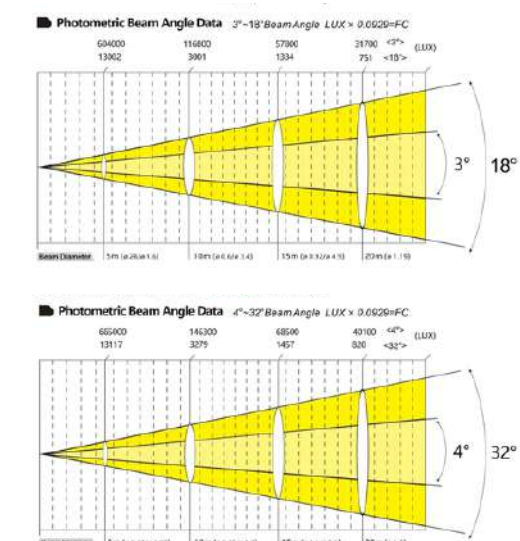

ROBUST 350

HYBRID CMY



More Designs



UPC# : 602835339398

HYBRID MOVING HEADS

ROBUST 350 HYBRID CMY



ELECTRICAL

- Power Supply: AC 100–240V, 50/60Hz auto-ranging
- Rated Power Consumption: 380W
- Power Connector: PowerCON TRUE1 In/Out
- Protection: Overheat, over voltage, and short-circuit protection

LIGHT SOURCE

- Type: White LED Engine, high output
- Power: 380W
- Color Temperature: 7200K (±300K)
- LED Lifetime: 20,000+ hours (L70)
- Flicker-Free: Yes (refresh rate adjustable for broadcast/video)

OPTICAL SYSTEM

- Zoom Range: 3° to 48° (Motorized linear zoom)
- Optical Precision: Anti-reflection coated lenses
- Focus: Motorized electronic focus
- Iris: Motorized with pulse & random strobe effects

COLOR SYSTEM

- CMY Color Mixing: Infinite full-color mixing (Cyan, Magenta, Yellow)
- CTO Filter: Linear color temperature correction
- Color Wheel: 8 dichroic colors + open, with bi-directional rainbow flow

GOBO SYSTEM

- Rotating Gobo Wheel:
 - 7 Interchangeable glass gobos + open
 - Indexable and rotatable with shake effect
- Static Gobo Wheel:
 - 10 static metal gobos + open
 - Gobo shake and scrolling

PRISM SYSTEM

- Prism 1: 5-facet Circular Rotating Prism
- Prism 2: 5-facet Linear Rotating Prism
- Dual Prism Layering: Yes – can overlay for complex multi-split effects
- Rotation: Bi-directional, indexable

FROST & DIFFUSION

- Frost Filter: Motorized for smooth wash transition
- Frost Mode: Linear control, ideal for soft stage washes

PAN & TILT

- Pan: 540° (16-bit resolution)
- Tilt: 270° (16-bit resolution)
- Feedback: Position auto-correction
- Movement Speed: Adjustable, fast/smooth mode

CONTROL & INTERFACE

- Control Modes:
 - DMX512 (3-pin & 5-pin XLR In/Out)
 - RDM Compatible
 - Optional ArtNET/sACN via upgrade module
- Control Channels: 21 / 24 / 27 DMX channel modes
- User Interface: Full-color LCD touchscreen with 180° flip
- Language Support: English, French, Spanish, Chinese

COOLING SYSTEM

- Intelligent thermal control with variable speed fans
- Temperature sensors with automatic fan curve adjustment
- Silent mode for theater environments

PHYSICAL

- Body Material: High-impact flame-retardant ABS + aluminum alloy
- IP Rating: IP20 (Indoor use)
- Rigging: 2x Quick-lock omega brackets included
- Display Flip: Yes (auto-detect orientation)
- Net Weight: 18.5 kg (40.7 lbs)
- Dimensions: 370 x 260 x 635 mm (LxWxH)

SAFETY / COMPLIANCE

- Certifications: CE, RoHS, CSA Compliant (for Canadian market)
- CSA Special Publication SPE-1000-21
- Safety Features: Thermal cutoff, head-lock transport, fixture reset



Scan the QR code for more product details

COLOR WHEELS

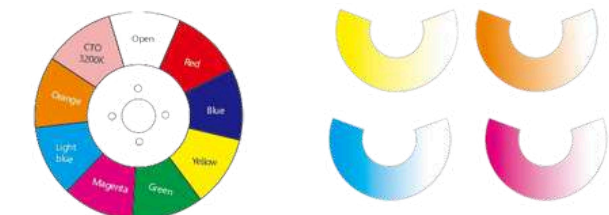

ROTATION GOBO

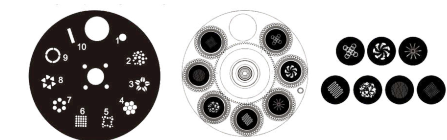

ILLUMINANCE

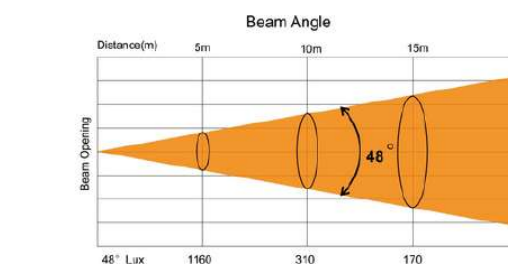
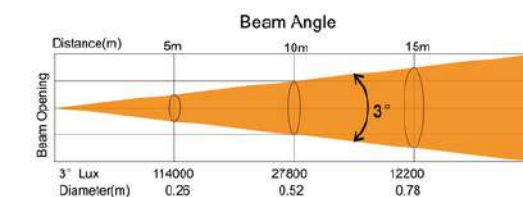

SIZE

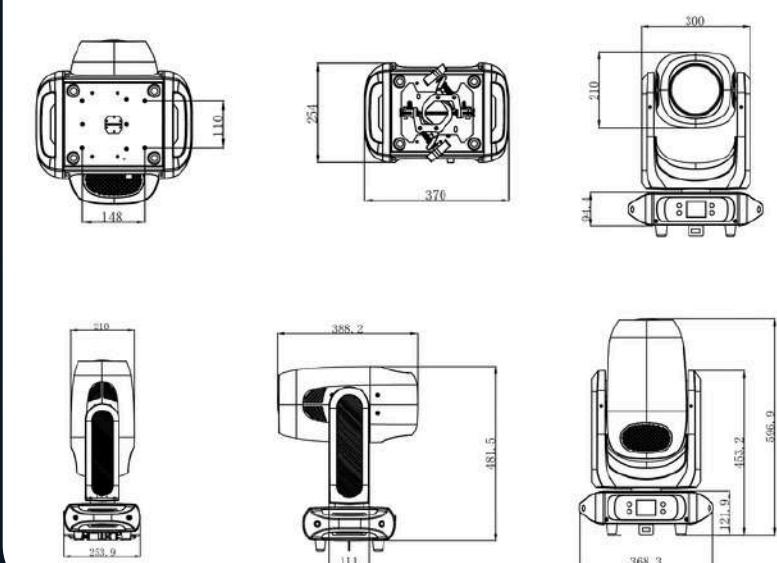

HYBRID MOVING HEADS

HYDREX APEX 830 BSWF



LIGHT SOURCE

- 680W White LED Module
- High brightness: Ra \geq 70, High Ra: Ra \geq 95
- Average Lifespan: 20,000 hours

POWER SYSTEM

- Power Consumption: 830W
- Signal: 3-pin XLR / 5-pin XLR
- DMX in/out: 3-pin XLR / 5-pin XLR
- Voltage: AC 100–240V, 50–60Hz

CONTROL

- 4 Touch Button Control
- LCD Display
- Control Protocols: DMX512, RDM
- DMX Channels: 32CH / 37CH

EFFECTS

- Beam Angle: 4°–45°
- Dimmer: 0–100% Linear Dimming
- Prism: 1x4 prisms, bidirectional rotation
- Framing: 4 blades with individual control, \pm 120° rotation
- Frost: 1 soft frost + 1 heavy frost (combinable)
- Strobe: 0–25 times/sec, high-speed electronic

MOVEMENT

- Pan: 540° (16-bit), bidirectional continuous rotation
- Tilt: 270° (16-bit), bidirectional continuous rotation

GOBO SYSTEM

- 7 interchangeable gobos + open
- Rotating gobo with shaking & positioning function
- 1 animation wheel (continuous rotation both directions)

COLOR SYSTEM

- 1 Color Wheel (5 colors + open)
- CTB + CRI
- Rainbow effect with bidirectional rotation
- CMY Linear Color Mixing
- CTO Linear Color Temperature Adjustment

PRODUCT SIZE & WEIGHT

- Product Size: 409 × 280 × 716.5 mm
- Net Weight: 29 kg
- Flight Case Size:
- 575 × 555 × 825 mm (1 unit)
- 950 × 570 × 820 mm (2 units)
- Gross Weight:
- 60 kg (1 unit)
- 102 kg (2 units)

IP RATING

- IP65

WORK ENVIRONMENT

- Maximum Ambient Temperature: 45°C
- Minimum Operating Temperature: -25°C

ROTATION GOBO



ILLUMINANCE

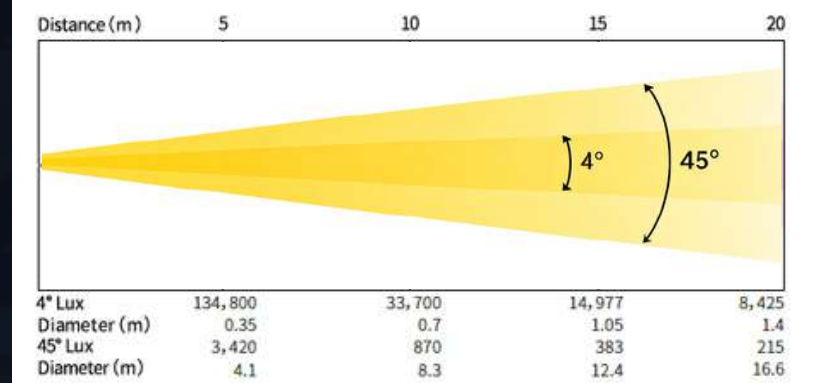

SIZE

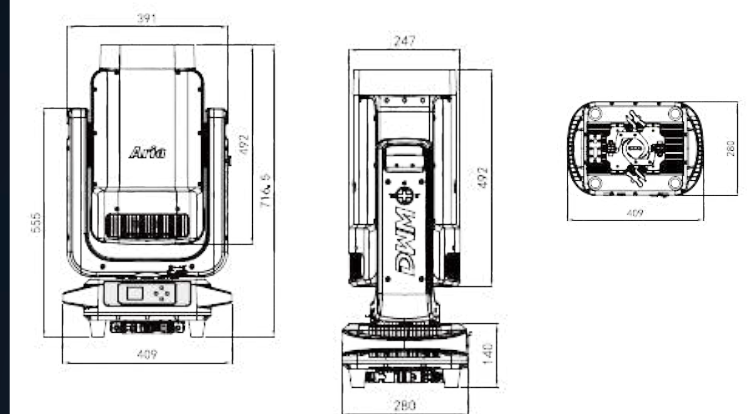

SHAFT

300 BEAM

BEAM MOVING HEADS

SHAFT 300 BEAM



LIGHT SOURCE

- PHILIPS MSD SILVER 3001L
- Color temperature: 7800K
- CRI: 86 (+/- 5)
- Beam Angle: 2°
- Diameter of optic lens: 145mm

COLOR WHEEL

- Color Wheel 1: 14 Colors+open, two way rainbow effect.
- Color Wheel 2: 7 Colourful Wheel

GOBO WHEEL

- 16 static GOBOS + Open (4 GOBOS are beam reducers)
- GOBO Shake Effect

PRISM WHEELS

- 2 Rotating prisms
- Equipped with 8 PRISM and 8+16+24 Honeycomb Prism,
- The two prisms can be stacked and rotated in both directions

CONTROL

- Protocols: DMX512 & RDM
- Control Mode: DMX512 & Manual (On-board Controls)
- 2 DMX Channel Modes: 18 Channels
- 2.4-inch Color screen with touch buttons
- 0-100% Smooth Dimming
- Various strobe speeds
- With Wired Digital Communication Network

PAN/TILT

- Pan: 540 degrees (plus 16-bit fine pan)
- Tilt: 270 degrees (plus 16-bit fine tilt)
- 3 Phase, SY Brand (XY axis magnetic coding positioning is more accurate)

CONNECTIONS

- DMX Connections: 3-pin DMX In/Out (5 pin optional) (Data link max: 32 fixtures)
- Power Connections: Outdoor locking In/Out connections to daisy chain power

ELECTRICAL

- Multi-voltage operation: 100-240V, 50/60Hz
- Max power consumption: 410W (@120V), 390W (@230V)
- Output Voltage : V1:36V(Master board), V2:12V(cooling fan),V3:380V(lamp)

DIMENSIONS & WEIGHT

- Dimension: 13.3" (L) x 10" (W) x 20" (H) / 338 x 256 x 515mm
- Weight: 33 lbs. / 14 kg.

APPROVALS / RATINGS

- CE
- CSA Special Publication SPE-1000-21
- FCC

WHAT'S INCLUDED

- 2M, 14AWG power cord

COLOR WHEEL

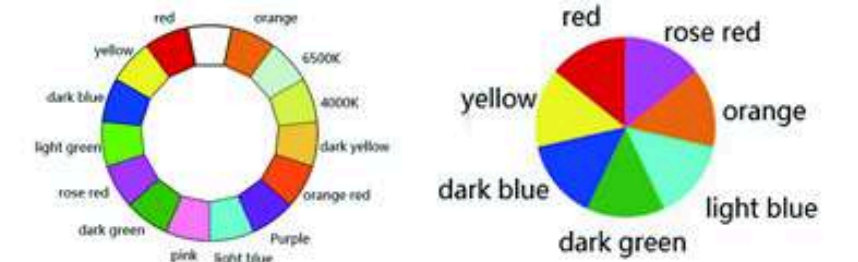

FIXED GOBO

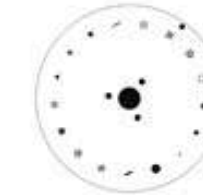

ILLUMINANCE

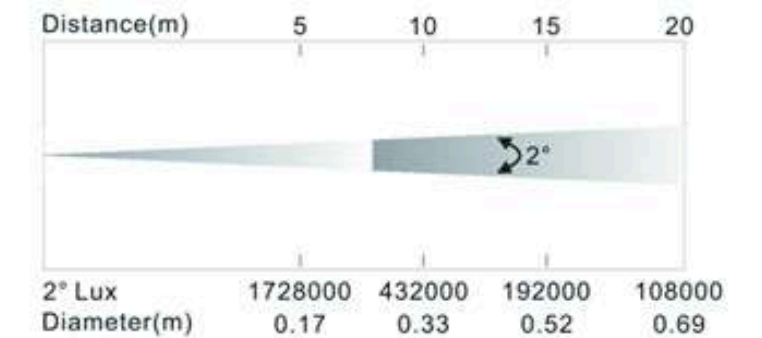

SIZE

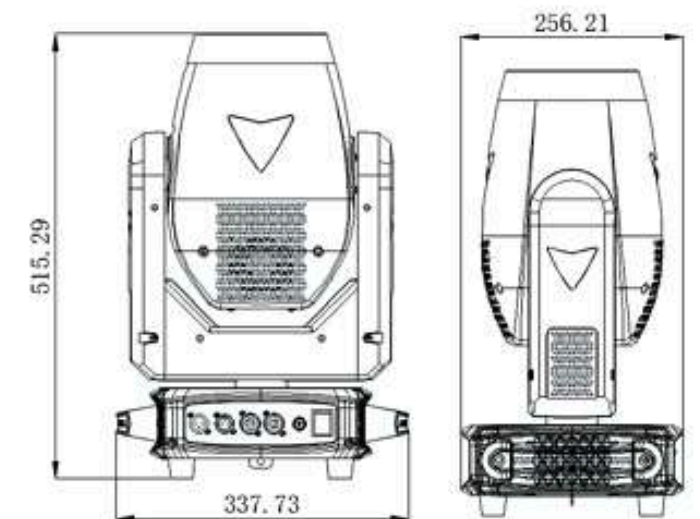

Scan the QR code for more product details

UPC# : 673324964947

ROBUST 200 BEAM



Scan the QR code for more product details

UPC# : 602835339388

BEAM MOVING HEADS ROBUST 200 BEAM

LIGHT SOURCE

- LED Type: OSRAM 200W LED Module
- Color Temperature: 8500K
- CRI (Color Rendering Index): ≥ 70
- Front Neon Ring: 30 x 0.2W 3-IN-1 RGB SMD LEDs
- Flicker-Free: Suitable for broadcast TV and film applications
- LED Life Span: Approx. 20,000 hours

OPTICAL SYSTEM

- Front Lens Diameter: $\varnothing 160\text{mm}$
- Beam Angle: 1.8°
- Optical Features: High-resolution optical system with smooth and precise linear focus

MOVEMENT (PAN & TILT)

PAN:

- 360° Continuous movement
- 540° (8/16-bit precision control)

TILT:

- 360° Continuous movement
- 270° (8/16-bit precision control)

Motors: Fast, quiet, and precise 3-phase motors

Additional Features:

- Auto repositioning after unexpected movement
- PAN/TILT reversible settings

COLOR SYSTEM

1 Color Wheel:

- 13 Dichroic Colors + Open
- Variable direction rainbow effect with adjustable speed

6-Color Wheel:

- Variable direction and speed control

GOBO SYSTEM

1 Static Gobo Wheel:

- 13 Static Gobos + Open

PRISM SYSTEM

Dual Prism Wheels

- Prism 1: 3 different prisms (5-facet linear, 8-facet circular, 4+8+16-facet circular prism)
- Prism 2: 3 different prisms (6-facet linear, 16-facet circular, 8+16-facet circular prism)
- Prism Indexing & Morphing for unique overlapping effects
- Variable speed and direction control

STROBE & DIMMING

Strobe: 0-25Hz shutter/strobe effect with variable speed

- 13 Static Gobos + Open
- Preset variable/random strobe and dimming pulse effects

Dimming: 0-100% smooth linear dimming

PHYSICAL SPECIFICATIONS

- Net Weight (N.W.): 13kg
- Gross Weight (G.W.): 15kg
- Product Dimensions: 261.8(D) x 297.9(W) x 513.7(H) mm
- Packing Dimensions: 655(D) x 380(W) x 355(H) mm

CONTROL SYSTEM

DMX Channel Modes: 23/25 Channels

Control Modes:

- DMX512
- Master-Slave Mode
- Auto Operation
- DMX Recorder & Edit Function

RDM Support: Yes (Remote Device Management)

Art-Net: Optional

Wireless DMX: Optional (built-in receiver system)

Signal Protection: Shielded input signal for stable transmission without interference

Connectivity

- 3-Pin & 5-Pin XLR DMX IN/OUT
- RJ45 etherCON IN/OUT (Optional with Art-Net)

SOFTWARE & DISPLAY SYSTEM

Software Update:

- Upgradeable via DMX daisy chain
- Multiple fixtures updatable simultaneously

Display System:

- 1.44" TFT LCD Display
- 5 Control Buttons
- 180° Reversible LCD Display
- Auto Display OFF Function
- DMX Signal Monitoring Indicator

COOLING & PROTECTION

- Cooling System: Advanced low-noise fan cooling with integrated aluminum heat dissipation
- Temperature Management: Constant temperature monitoring and over-temperature protection

POWER & ELECTRICAL

- Power Supply: AC 100-240V, 50/60Hz
- Power Consumption: 290W
- Power Connectors: PowerCON IN/OUT with fuse
- Active Power Factor Correction (PFC): Yes

HOUSING & BUILD

Material:

- High-tension molded fireproof ABS PC housing
- Aluminum and steel internal structure

Handles: Two ergonomic side handles on base

Color Finish: Black

INSTALLATION & MOUNTING

Omega Clamps:

- 2 x 1/4 Turn Fastening Omega Clamps (adaptable for vertical & horizontal mounting)

Safety Point: 1 x Safety Attachment Point

Operating Positions: All (floor-standing or rigged installations)

ENVIRONMENTAL CONDITIONS

- Operating Temperature: -25°C to 45°C
- IP Rating: IP20 (Indoor use only)

COMPLIANCE & CERTIFICATIONS

- LVD (2014/35/EU): Safety of electrical equipment supplied at low voltage
- EMC (2014/30/EU): Electromagnetic Compatibility
- RoHS (2011/65/EU): Restriction of hazardous substances
- CSA Special Publication SPE-1000-21



DIMENSIONS

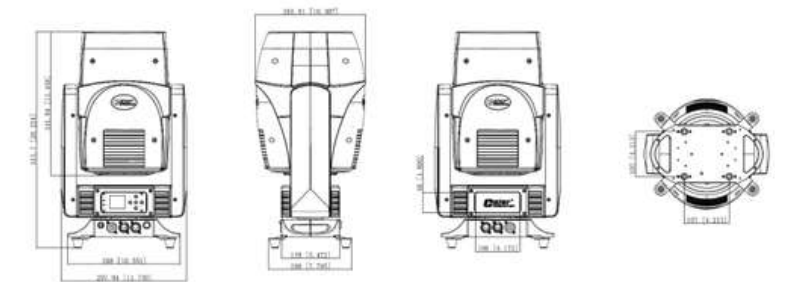

EFFECT



6-Color Wheel



Color wheel

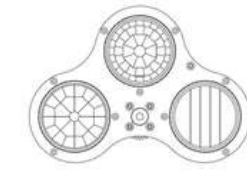

Prism 1: 3 different prisms, 5-Facet linear prism/8+16-Facet circular prism/8+16+24-facet circular prism with variable speed and direction

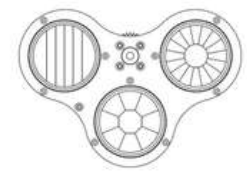

Prism 2: 3 different prisms, 6-Facet linear prism/8-facet circular prism/16-facet circular prism with variable speed and direction

GOBO



PHOTOMETRIC

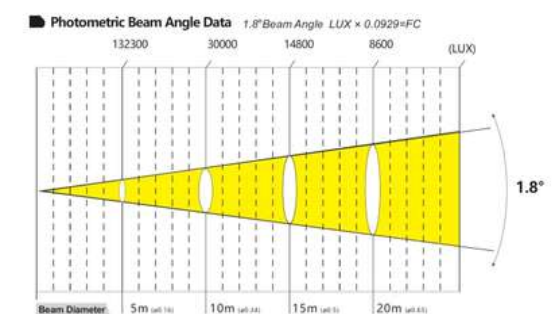

BEAM MOVING HEADS

SHAFT 420 BEAM

SHAFT 420

BEAM



LIGHT SOURCE

- Lamp Type: OSRAM SIRIUS HRI 420W
- Auxiliary LEDs: 30x0.2W 3-IN-1 RGB SMD LEDs (Front Ring Neon Strip)
- Color Temperature: 7850K (±300K)
- CRI (Color Rendering Index): ≥ 83 (±5)
- Flicker-Free Operation: Optimized for TV and Film
- Lamp Life Span: Approx. 2500 hours (varies based on environmental conditions, voltage, usage patterns, and control settings)

OPTICAL SYSTEM

- Optics: High-resolution, precise optical system
- Front Lens: Ø160mm
- Beam Angle: 1.8°
- Focus: Smooth, linear motorized focus

MOVEMENT

- Pan:
 - 360° Continuous
 - 540° (8/16-bit resolution)
- Tilt:
 - 360° Continuous
 - 270° (8/16-bit resolution)
- Motors: 3-Phase stepper motors (fast, quiet, precise)
- Features:
 - Auto repositioning
 - Position memory
 - Reversible PAN/TILT

COLOR SYSTEM

- Color Wheel: 13 dichroic colors + open
- 6-Color Wheel: With variable speed and direction
- Rainbow Effect: Bi-directional, variable speed

GOGO & EFFECTS SYSTEM

Gobo Wheel: 13 static gobos + open

Prism Wheel 1:

- 5-Facet Linear Prism
- 8-Facet Circular Prism
- 4+8+16-Facet Circular Prism

Prism Wheel 2:

- 6-Facet Linear Prism
- 16-Facet Circular Prism
- 8+16-Facet Circular Prism

STROBE & DIMMING

- Strobe: 0-25Hz with pulse/random effects
- Dimming: 0-100% smooth linear dimming

CONTROL & CONNECTIVITY

- DMX Channels: 23/25 channels (USITT DMX-512)
- Control Modes: DMX512, Master-Slave, Auto Mode
- RDM (Remote Device Management): Available
- Art-NET: Optional
- Wireless DMX Receiver: Built-in (Optional)
- Signal Protection: Shielded input for stable signal without interference
- Connectors:
 - DMX: 3-pin & 5-pin XLR IN/OUT
 - Network: RJ45 etherCON IN/OUT (optional with Art-Net)
 - Software Update: Upgradable via DMX connectors (multi-unit daisy-chain update)

DISPLAY & INTERFACE

- Screen: 1.44" TFT LCD Display
- Control Buttons: 5-button navigation
- Screen Rotation: 180° reversible display
- Auto-Off: Display turns off when inactive
- Signal Indicator: DMX signal monitoring

COOLING SYSTEM

- Self-Adjusting Fan Cooling: Efficient low-noise operation
- Temperature Monitoring: Constant readout & management
- Over-Temperature Protection: Prevents overheating for long lifespan

POWER SUPPLY

- Electronic Ballast: PT-SIRIUS 310W with Active PFC
- Voltage: AC100-240V, 50/60Hz
- Power Consumption: 630W
- Power Connections: PowerCON IN/OUT with fuse protection

HOUSING & BUILD QUALITY

- Material: Fireproof PA6 + fiber-reinforced plastic with aluminum & steel plates
- Handles: Dual side handles for easy handling
- Color: Matte black exterior

INSTALLATION & RIGGING

Mounting Options:

- Omega Clamps: 2x 1/4 turn fastening (vertical & horizontal adaptable)
 - Safety Attachment Point: Available for secure rigging
- Operating Positions: Any (floor-mounted or truss-mounted)
- Operating Temperature: -25°C to 45°C
 - IP Rating: IP20 (indoor use)

ENVIRONMENTAL CONDITIONS

- Operating Temperature: -25°C to 45°C
- IP Rating: IP20 (indoor use)

DIMENSIONS & WEIGHT

- Product Dimensions: 261.8mm (D) x 297.9mm (W) x 513.7mm (H)
- Packing Dimensions: 655mm (D) x 380mm (W) x 355mm (H)
- Net Weight: 13.6 kg
- Gross Weight: 15.6 kg

COMPLIANCE & CERTIFICATIONS

- CE Certification
- LVD (2014/35/EU): Safety of electrical equipment supplied at low voltage
- EMC (2014/30/EU): Electromagnetic Compatibility
- RoHS (2011/65/EU): Restriction of hazardous substances
- CSA Special Publication SPE-1000-21



Scan the QR code for more product details

COLOR WHEEL

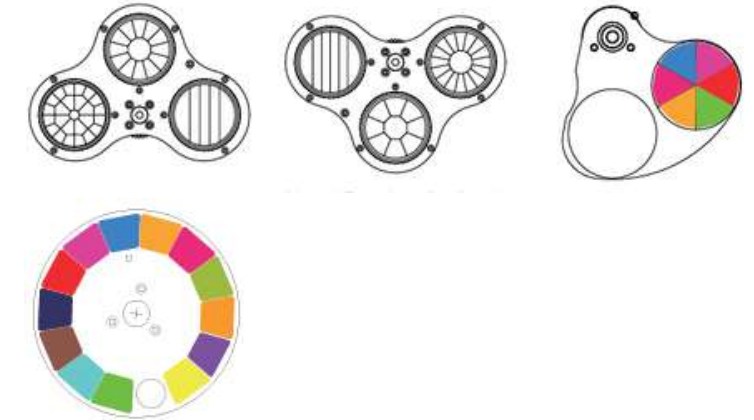

ROTATION GOGO

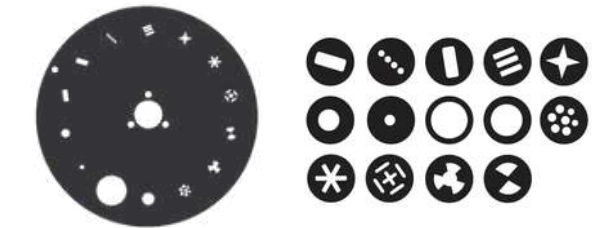

SIZE

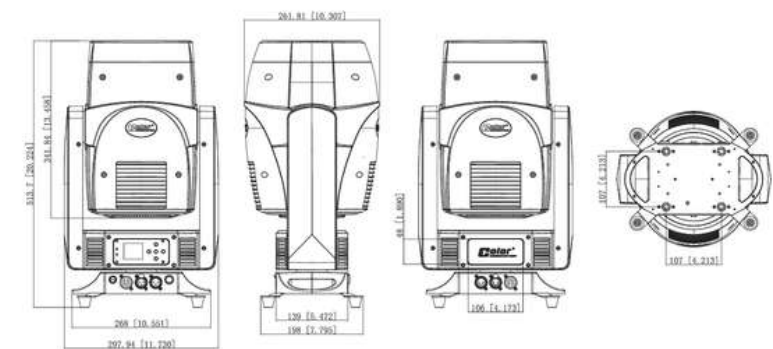

PHOTOMETRIC

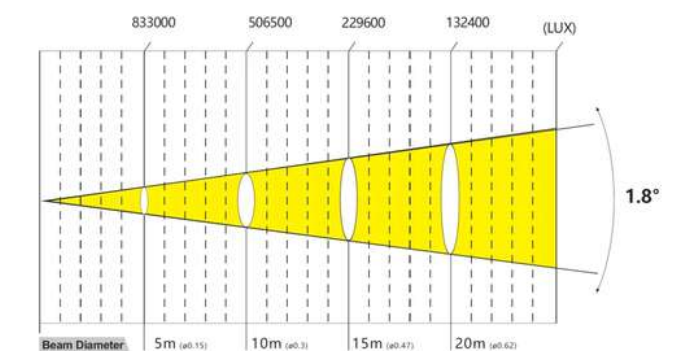

UPC# : 602835339371

HYDREX BEAMFORCE 420



BEAM MOVING HEADS HYDREX BEAM FORCE 420



IP RATING

- IP66

POWER SUPPLY

- AC100 - 240V, 50/60 Hz
- Power consumption: 530 W 220V

LIGHT SOURCE

- USHIO NSLU7A 420W
- Average life: 4000+ hrs long lifespan
- Color temperature: 6800K

COLOR SYSTEM

- Pan/Tilt: 540/270°
- Control mode: DMX512/RDM
- DMX channels: 16
- Powercon: Seetronic Power in & out
- XLR in & out: 3 pin
- IP Rating: IP66

HOUSING

- Magnesium alloy
- Black matte fine sand outdoor paint
- Salt corrosion resistance

PACKED

- Net weight: 20kg

EFFECT

- Beam angle: 2°, 750,000 lux @ 10m
- Lens diameter: 180mm
- Color wheel: 13 colors + white
- Fixed gobo wheel: 15 gobos + white
- Prism: 8-facet + 8-facet + 24-facet
- Prism overlay, 7 types prism
- Frost filter for soft-edge projection
- Focusing: 0-100% linear
- Dimming: 0-100% linear
- Strobe: 1-12 Hz, random and pulse flash

COLOR WHEEL

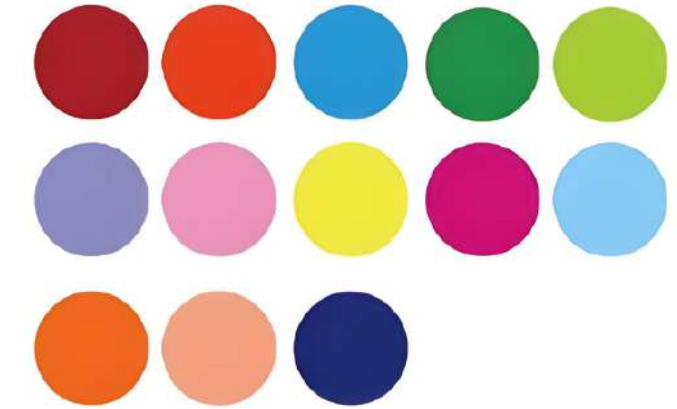

ROTATION GOBO

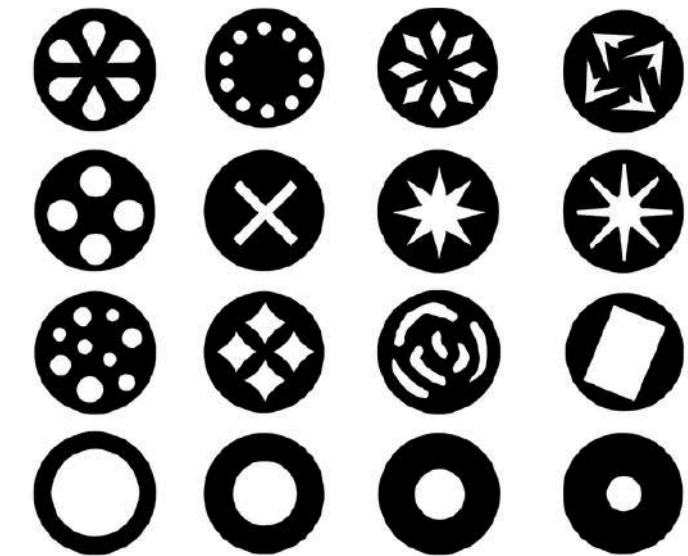

PHOTOMETRIC

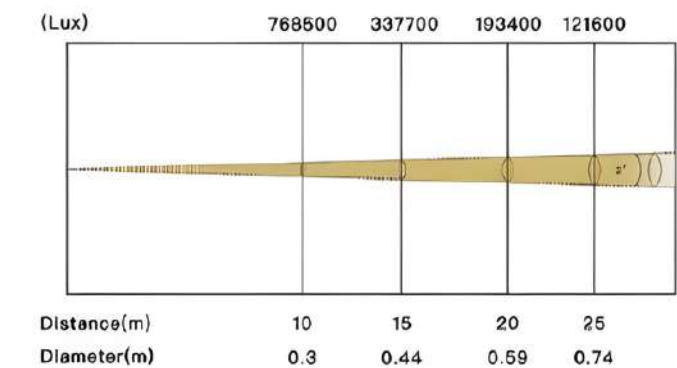

Scan the QR code for more product details

Rumble

M4 SPOT

SPOT MOVING HEADS

RUMBLE M4 SPOT



LIGHT SOURCE

- Type: High-intensity white LED
- Power Rating: 200W
- Lumen Output: High-output (brightness varies by beam angle and optics)
- LED Lifetime: Up to 20,000 hours
- Color Temperature: Approx. 7500K
- Flicker-Free: Suitable for broadcast and filming

OPTICAL SYSTEM

- Beam Angle: 22°
- Optical Design: Precision glass optics for sharp gobo projection
- Zoom: Motorized
- Focus: Motorized
- Lens Type: Anti-reflective coated high-efficiency lens

COLOR SYSTEM

- Color Wheel: 1 wheel with 8 vibrant dichroic colors + open
- Color Effects: Rainbow chase effect, split colors, smooth transitions
- Color Mixing: Through fast color wheel transitions

GOBO SYSTEM

- Static Gobo Wheel: 8 metal gobos + open
- Rotating Gobo Wheel: 8 indexable, interchangeable high-resolution glass gobos + open
- Gobo Effects: Gobo shake, gobo scroll, indexing, bidirectional rotation
- Gobo Size: Standard size for custom gobos

PRISM & EFFECTS

- Prism: 4-facet rotating prism, bi-directional
- Prism Speed: Variable, controllable via DMX
- Layering: Can combine with gobos and colors for aerial beam effects
- Other Effects: Frost emulation via focus/zoom layering, strobe (1-20 Hz), blackout

MOVEMENT

- Pan: 540°, 16-bit fine control
- Tilt: 270°, 16-bit fine control
- Position Feedback: Auto repositioning
- Movement Speed: Fast with smooth acceleration/deceleration curves

200W WHITE LED LIGHT SOURCE

- Energy-efficient and powerful
- Long-lasting (up to 20,000 hours) for reduced maintenance
- Bright output suitable for mid- to large-scale venues

PRISM & EFFECTS

- Prism: 4-facet rotating prism, bi-directional
- Prism Speed: Variable, controllable via DMX
- Layering: Can combine with gobos and colors for aerial beam effects
- Other Effects: Frost emulation via focus/zoom layering, strobe (1-20 Hz), blackout

ENVIRONMENTAL

- Operating Temperature: 0°C to 55°C
- Storage Temperature: -10°C to 60°C
- Cooling System: Intelligent, temperature-regulated fan cooling
- IP Rating: IP20 (for indoor use only)
- Mounting: Dual locking brackets for truss or floor placement
- Orientation: Operates in any position

200W WHITE LED LIGHT SOURCE

- Energy-efficient and powerful
- Long-lasting (up to 20,000 hours) for reduced maintenance
- Bright output suitable for mid- to large-scale venues

PRECISION OPTICAL SYSTEM

- Beam angle of 22° ensures balanced spread with punch
- Motorized zoom and focus allow live adjustments for beam size and clarity
- High-definition gobo projection at long throw distances

DUAL GOBO WHEELS

- Rotating Gobo Wheel: 8 replaceable, rotating glass gobos for dynamic projection
- Static Gobo Wheel: 8 fixed gobos for quick textured effects and gobo chase
- High-precision indexing and shake functions

4-FACET ROTATING PRISM

- Bi-directional rotation for creative beam splitting
- Multiplies single beam into dynamic aerial patterns
- Adds motion and volume to your lighting scenes

PROFESSIONAL CONTROL & COMPATIBILITY

- DMX512 + RDM compatibility
- 16 DMX control channels
- LCD display for intuitive on-board configuration
- 3-pin XLR in/out for universal data connectivity

SMOOTH, FAST MOVEMENT

- 540° pan and 270° tilt with 16-bit resolution
- Fast repositioning with auto correction
- Ideal for tracking, spotighting, or synchronized beam movement

COMPACT YET POWERFUL DESIGN

- Power consumption: 280W
- Operates from 100-240V AC (auto-switching)
- Lightweight (10.5 kg) for easy rigging and touring
- IP20 rated for indoor environments

ELECTRICAL

- Input Voltage: AC 100-240V, 50/60Hz (Auto-ranging)
- Power Consumption: Max. 280W
- Power Factor: ≥ 0.95
- Protection: Overload, overheat, and short-circuit protection

COLOR SYSTEM

- 1 color wheel with 8 vibrant dichroic filters
- Seamless color blending and rainbow chase effect
- Delivers dynamic scenes from bold color washes to subtle transitions

CONTROL & INTERFACE

- Protocols: DMX512, RDM (Remote Device Management)
- Control Channels: 16 DMX channels
- Display: Backlit LCD with 4-button menu navigation
- Connectivity:
 - DMX In/Out: 3-pin XLR
 - Power Input: PowerCon-compatible socket
 - DMX address, fan control, mode selection, motor reset

SAFETY / COMPLIANCE

- Certifications: CE, RoHS.
- CSA Special Publication SPE-1000-21
- Safety Features: Thermal cutoff, head-lock transport, fixture reset

RDM DMX512 频闪 彩虹 调光 主从

Total power
280W

Channel
16CH

Weight
10.5KG



Scan the QR code for more product details

UPC# : 602835339708

RUMBLE BEAM 360



SPECIFICATIONS

- Voltage: AC100-240V 50/60Hz
- Light source: 100W Super brightness LED, 24Pcs RGB 3in1 SMD LED
- Power consumption: 150W
- Operating mode: DMX512, RDM, master-slave, automatic, sound control
- Control channel: 16 channels / 20 channels
- Dimming: 0-100% LED Linear dimming
- Strobe: High-speed electronic strobe
- Pan/Tilt: 540°/270° (16bit)
- Gobo wheel: 13 gobos
- Colour wheel: 12 colours + white, half colour, rainbow effect
- Prism: 8 prism
- Six-colour wheel: Can make colourful prism effect
- Focusing: Electronic focusing
- Beam angle: 2-3°
- Display board: Colour screen LCD display, forward and reverse display
- Size: 22.52|36 CM
- Certification: CSA Special Publication SPE-1000-21



Scan the QR code for more product details

RUMBLE 4040 B-EYE



SPECIFICATIONS

- Voltage: AC100-240V 50/60Hz
- Light source: 100W Super brightness LED, 24Pcs RGB 3in1 SMD LED
- Power consumption: 150W
- Operating mode: DMX512, RDM, master-slave, automatic, sound control
- Control channel: 16 channels / 20 channels
- Dimming: 0-100% LED Linear dimming
- Strobe: High-speed electronic strobe
- Pan/Tilt: 540°/270° (16bit)
- Gobo wheel: 13 gobos
- Colour wheel: 12 colours + white, half colour, rainbow effect
- Prism: 8 prism
- Six-colour wheel: Can make colourful prism effect
- Focusing: Electronic focusing
- Beam angle: 2-3°
- Display board: Colour screen LCD display, forward and reverse display
- Size: 22.52|36 CM
- Certification: CSA Special Publication SPE-1000-21



Scan the QR code for more product details

Rumble
Spot Wash 360

SPOT MOVING HEADS

RUMBLE SPOT WASH 360



SPECIFICATION

- Voltage: AC100-240V 50/60Hz
- Light source: 120W super brightness LED, 7*RGBW 4 in 1 LED (can be used for wash effect)
- Power consumption: 200W
- Operating mode: DMX512, RDM, master/slave, automatic, sound
- Control channels: 16 channels / 20 channels
- Dimming: 0-100% linear dimming
- Strobe: High-speed electronic strobe
- Pan/Tilt: 540°/270°
- Rotating gobo wheel: 8 (6 metal gobos + 2 glass gobos)
- Fixed gobo wheel: 8
- Effect wheels: Prism effect, color wheel, half color, rainbow effect
- Prism: 3-facet prism
- Focusing: Electronic focusing spot
- Weight: 8.5 KG
- Dimensions: 32 x 22 x 52 cm
- Display: 2.5" display panel color screen LCD display, forward and reverse display
- Certification: CSA Special Publication SPE-1000-21



Scan the QR code for more product details

VISTA 1925 XR



LIGHT SOURCE

- Powered by 19 x 25-watt OSRAM LED modules with 4-in-1 RGBW color mixing.
- Outstanding CRI >95 ensures true-to-life color rendering.
- Motorized zoom with a beam angle range of 10° to 60° for ultimate flexibility.
- Adjustable color temperature from 2,500K to 10,000K, perfect for any application.

EFFECTS

- Dynamic RGBW color mixing for vivid and precise hues.
- 3-pixel control allows independent operation of outer, inner rings, and the center LED.
- Smooth linear dimming and variable strobe effects up to 25Hz.
- Choice of 4 dimmer curves to adapt to various lighting styles.
- Pan and Tilt movement: 540° Pan and 270° Tilt with 16-bit resolution for fast, precise positioning.

TECHNICAL SPECIFICATIONS

- Power Input: AC100–240V, 50/60Hz.
- Power Consumption: Max 430 watts.
- Rated IP20, designed for indoor use only.
- Silent operation with a noise level under 40 dB.
- Long-lasting LEDs with an average lifespan of 50,000 hours.
- Automatic repositioning of the yoke for added reliability.
- RDM compatible for advanced remote management.
- Equipped with 3-phase motors for precise and fast movements.
- Easy-to-use Blue/White LCD display for menu navigation.
- PowerCon connectors for daisy-chaining up to 9 fixtures at 230V.

DIMENSIONS & WEIGHT

- Fixture dimensions: 350 x 200 x 400 mm.
- Net weight: 9.5 kg.
- Packing size: 470 x 265 x 565 mm.
- Gross weight: 11 kg.

CERTIFICATION

- CSA Special Publication SPE-1000-21



Scan the QR code for more product details

UPC# : 67332496522

740 MINI WASH



LIGHT SOURCE & OPTICS

- Powered by 7 x 40W RGBW 4-in-1 LEDs for vivid color performance.
- Motorized zoom range: 6° – 45°, allowing both narrow beams and wide washes.
- Smooth linear dimming from 0–100% with selectable dimming curves.
- Flicker-free performance suitable for live shows and video recording.

EFFECTS

- Combination of beam + wash effects in one fixture.
- Four dimming curves for flexible control of light transitions.
- High-speed and accurate pan (540°) / tilt (270°) movements with 16-bit resolution.
- Quiet operation, ideal for theatrical or studio applications.

TECHNICAL SPECIFICATIONS

- Power Consumption: 250W
- Control Modes: DMX512, RDM, Auto-run, Sound Active, Master/Slave
- DMX Channel Modes: 17/22 channels
- Display: LCD screen for easy configuration
- Connections: 3-pin XLR data in/out, PowerCon in/out
- Protection Rating: IP20 (indoor use)

DIMENSIONS & WEIGHT

- Dimensions: 258 x 178 x 334 mm
- Net Weight: 5.5 kg
- Rugged and lightweight housing for touring and installations.

CERTIFICATION

- CSA Special Publication SPE-1000-21



Scan the QR code for more product details

COLORSHAFT C12



Total power 550W	Channel 15/63CH	Weight 17.9KG
----------------------------	---------------------------	-------------------------

点阵	RDM	DMX512	频闪
彩虹	调光	主从	



Scan the QR code for more product details

UPC# : 602835339715

LIGHT SOURCE

- LED: 12 × 40W RGBW 4-in-1 LEDs
- LED Lifespan: 50,000 hours
- Beam Aperture: 3° narrow beam
- Zoom Range: 3°–50° (Motorized)
- Optics: Dual 65mm precision front lenses
- Color Rendering Index (CRI): High CRI, suitable for stage & camera
- Dimming: Electronic, 0–100% linear
- Strobe: 1–20 flashes/sec

POWER & ELECTRICAL

- Voltage: AC100V–240V, 50/60Hz
- Max Power Consumption: 550W
- CSA Certified: Yes

MOVEMENT

- Tilt Range: 140°
- Tilt Resolution: 8-bit and 16-bit smooth movement
- Motor: High-precision, low-noise stepper motor

EFFECTS & CONTROL

- Pixel Control: Yes, individual LED control
- Effects: Built-in 2D & 3D visual FX, dynamic color macros
- Control Protocols: DMX512, RDM
- DMX Channel Modes: 15 / 63 channels
- Display: Full-color LCD with 180° flip
- Built-in Programs: Yes
- Installation Modes: Floor mount or rigging

CONSTRUCTION

- Body: High-strength aluminum housing
- Cooling: Intelligent fan cooling
- Mounting: Omega brackets and safety points

PHYSICAL

- Dimensions: 1010 × 296 × 130 mm
- Net Weight: 17.9 kg

HIGH-POWERED LED OUTPUT

- Equipped with 12 × 40W RGBW 4-in-1 LEDs
- Delivers bright, vivid, and color-accurate output
- Rated lifespan of 50,000 hours

PRECISION MOVEMENT

- 140° tilt range with both 8-bit and 16-bit control resolution
- Quiet & smooth operation—ideal for live performance environments

ADVANCED COLOR & BEAM CONTROL

- Motorized Zoom Range: 3° narrow beam to 50° wide wash
- Individually controllable pixels for advanced FX and pixel mapping
- Smooth 0–100% electronic dimming and dynamic strobe (1–20 Hz)
- Sophisticated color mixing with high CRI for excellent color rendering

CREATIVE EFFECTS ENGINE

- Built-in 2D & 3D visual effects, chases, and macros
- Compatible with beam, wash, and matrix-style effects
- Ideal for stage design, touring shows, nightclubs, and AV installations

PROFESSIONAL CONTROL OPTIONS

- Supports DMX512 & RDM protocols
- Selectable 15 or 63 DMX channel modes for flexible programming
- Full color LCD interface with 180° rotation for easy access rigging

BUILT FOR THE NORTH AMERICAN MARKET

- CSA Special Publication SPE-1000-21
- Built for safe, reliable use in permanent setups & rentals across Canada & U.S.

LED MOVING HEADS

COLORSHAFT FX-ONE

LIGHT SOURCE

- LEDs: 960 × RGB 0.5W + 300 × White/Gold 2-in-1 2W LEDs
- Color Temperature: 6670K
- CRI (Warm White): 73
- Lumen Output: [Optional: specify if available]
- RGB Pixel Control: 80 pixel-mappable zones
- White Pixel Control: 10 segment strobe zones

MOVEMENT

- Pan: 540° (16-bit resolution)
- Tilt: 270° (16-bit resolution)
- Movement Features: Smooth, multidimensional motion for stage, touring, and installations

CONTROL & PROGRAMMING

Control Protocols: DMX512, RDM

DMX Channel Modes:

- 24 CH – Basic Operation
- 266 CH – Advanced FX Mode
- 284 CH – Full Pixel Mapping Mode

Standalone Operation:

- 255-step dimmer via LCD
- Built-in auto programs for plug-and-play operation

Display: Backlit LCD with menu navigation

Connectors:

- 3-pin XLR DMX In/Out (Panel Mounted)
- PowerCON® In/Out (Panel Mounted)

ELECTRICAL SPECIFICATIONS

- Power Supply: Universal 100–240V AC, 50/60Hz (Auto-switching)
- Power Consumption: 590W
- Current Draw: 5.04A @ 110V

MECHANICAL SPECIFICATIONS

- Fixture Size: 24.5" L × 7.6" W × 14.5" H
- Fixture Weight: 36 lb (16.33 kg)
- Packaged Size: 27.36" × 9" × 17.25"
- Packaged Weight: 38.6 lb (17.5 kg)
- Mounting: 2 × Quick-Release Clamp Mounts
- IP Rating: IP20 (Indoor Use Only)

THERMAL & ENVIRONMENTAL

- Max Ambient Temperature: 104°F (40°C)
- Max Surface Temperature: 140°F (60°C)

CERTIFICATIONS & COMPLIANCE

- CSA Special Publication SPE-1000-21
- CE Compliant
- RoHS Compliant
- ETL/cETL Pending (Optional upon request)



Total power 950W	Channel 22/255 CH	Weight 14.9KG
----------------------------	-----------------------------	-------------------------

ARTNET	点阵	RDM	DMX512	单独控制
频闪	调光	主从	彩虹	



Scan the QR code for more product details

UPC# : 60283533692

COLORSHAFT CRYSTAL



LIGHT SOURCE

- 150 × 0.25W RGB 3535 SMD LEDs
- LED lifespan: 50,000 hours (approx.)

MOVEMENT

- PAN: 360° continuous, 8/16-bit
- TILT: 360° continuous, 8/16-bit
- Fast and quiet 3-phase motors
- Scan position memory and auto-reposition

CONTROL

- DMX Channels: 13 / 22 / 190
- Protocols: DMX512, RDM, Art-Net
- Operation modes: Auto, Sound, Master-Slave, DMX
- Adjustable sound sensitivity
- Multi-preset internal programs
- Integrated DMX recorder/edit function

COOLING SYSTEM

- Natural cooling for head
- Auto-adjusting fan for base
- Constant temperature readout & overheat protection

EFFECTS

- RGB color mixing
- Rotating wings for blackhole simulation effect
- Strobe: 0-25Hz, random & pulse effects
- Pixel mapping capabilities

DIMMING SYSTEM

- 0-100% linear dimming
- 4 dimming curves: Standard, Linear, Square Law, Inverse Square Law
- Dimming reversible



DISPLAY

- 2.8" TFT LCD with adjustable brightness
- English / Chinese menu
- 4-button control interface
- 180° reversible display with auto-off function

POWER

- AC100-240V, 50/60Hz
- Power consumption: 550W
- PowerCON IN/OUT
- Active PFC electronic power supply
- Fuse protected

CONSTRUCTION

- Fireproof ABS + PC housing with aluminum and steel structure
- Two side invisible handles
- Black exterior finish

INSTALLATION

- 2 × 1/4 turn Omega brackets
- 1 safety attachment point
- Mountable in all positions (floor or truss)

OPERATING CONDITIONS

- Temperature: -25°C to 45°C
- IP Rating: IP20 (indoor use)

CONSTRUCTION

- CE Certified

DIMENSIONS & WEIGHT

- Product Size: 270(L) × 560(W) × 601(H) mm
- Packing Size: 300(L) × 600(W) × 680(H) mm
- Net Weight: 16.9 kg
- Gross Weight: 19.7 kg

CERTIFICATION

- CSA Special Publication SPE-1000-21

COLORSHAFT C9MH WASH + STROBE

POWER

- Power Supply: AC100-240V, 50/60Hz
- Power Consumption: 550W (Max)

LIGHT SOURCE

- Light Source: 9×40W RGBW LEDs + 480×0.5W RGB LEDs
- LED Lifespan: 50,000 hours

OPTICS

- Beam aperture 3°-60°, 25 squared 65mm frontal lens

STROBE ANGLE

- 120°

COLOURS

- 4-colour RGBW mixing, uniform light beam with no colour shadows, high saturation and pastel tones

DIMMING

- Dimming: 0-100% electronic dimming
- Strobe Speed: 1-25 flashes per second

MOVEMENT

- Infinite pan & tilt rotation, 8/16-bit resolution

EFFECTS

- 2D & 3D graphical effects, compatible with beam, wash, strobe, and matrix applications

CONTROL PROTOCOLS

- Control Protocols: DMX512 / RDM
- Control Channels: 23 / 133 CH

DISPLAY

- Full-colour LCD (reversible 180°)

DIMENSIONS

- Dimensions: 457×360×295 mm
- Net Weight: 16.2 kg

CERTIFICATION

- CSA Special Publication SPE-1000-21



Total power 550W	Channel 23/133 CH	Weight 16.2KG
----------------------------	-----------------------------	-------------------------



Scan the QR code for more product details



Scan the QR code for more product details

ROAR THUNDER



POWER

- Power Voltage: AC 100–240V, 50/60Hz
- Power Consumption: 1400W

LIGHT SOURCE

- 768 pcs 1.5W White Color LEDs
- 528 pcs 1.5W RGB 3-in-1 LEDs

PIXEL MATRIX

- White: 4 × 12 Groups
- Color RGB: 3 × 6 Groups

LUMEN FULL OUTPUT

- R: 5480 Lm
- G: 11760 Lm
- B: 1560 Lm
- W: 45000 Lm
- Total Output: 63880 Lm

OTHER SPECIFICATIONS

- CRI: Ra ≥ 90
- Light Source Life: 20,000 hours
- Beam Angle: 110°
- Frost: DMX Frost
- Dimmer: 0–100% Linear Dimmer

CONTROL

- Display: LCD Display
- DMX Channels: 25 / 34 / 68 / 114 / 130 / 170 CHs
- Control Modes: DMX512, Auto, Master-Slave, Music
- Display: Illuminated Graphic LCD
- Protocol: Art-Net, DMX-512, RDM
- RDM: Bidirectional Communication
- Cooling: Temperature Controlled, Overheating Protection

CONSTRUCTION

- DMX In/Out Socket: Seetronic 3-pin XLR Waterproof In/Out
- Power Socket: Seetronic Waterproof PowerCON In
- Art-Net: Seetronic Waterproof Art-Net In/Out
- Housing: Die-casting Aluminum Housing

PHYSICAL

- Protection Rating: IP65
- Product Size: 404 × 202 × 350 mm
- Weight: 15 kg



Scan the QR code for more product details

ROAR STORM



ELECTRICAL & POWER

- Power Voltage: AC 100–240V, 50/60Hz
- Power Consumption: 1000W

LIGHT SOURCE

- Light Sources: TX high quality 4-in-1 RGBW 5060 40W × 24 pcs + 24 pcs × 6W RGBW 4-in-1 LEDs
- Pixel Matrix: Main LED and Auxiliary LED both can be controlled individually
- CRI: Ra ≥ 80
- CTO: 2800–8000K
- Light Source Life: 50,000 hours

BEAM ANGLE

- Main LED: 12°
- Main LED with E-frost: 48°
- Auxiliary LED: 110°
- Auxiliary LED with E-frost: 106°
- Combined: 12°
- Combined with E-frost: 50°

EFFECTS

- Dimmer: 0–100% linear dimmer
- Strobe: 0.5–25 times/second and random strobe

CONTROL

- DMX Channels: 29 / 222 / 314 / 30 / 144 / 192 / 240 / 288 / 72 / 96 / 120 / 144
- Protocol: Art-Net, DMX-512, RDM
- Display: Illuminated graphic LCD
- RDM: Bidirectional communication
- Cooling: Temperature controlled, overheating protection

CONSTRUCTION

- DMX In/Out Socket: Seetronic 3-pin XLR waterproof in/out
- Power Socket: Seetronic waterproof Powercon in/out
- Art-Net: Seetronic waterproof Art-Net in/out
- Housing: Die-casting aluminum body housing

PHYSICAL SPECIFICATIONS

- Protection Rating: IP65
- Product Size: 404 × 202 × 350 mm
- Weight: 15 kg
- Packing Size (Carton): 490 × 240 × 420 mm



Scan the QR code for more product details

COLORSHAFT CURVY PRO



LIGHT SOURCE

- RGBW LED: 600W
- Cool White LED: 120W
- Warm + Cool White LED: 1440W

OPTICAL SYSTEM

- Beam Angle:
- 4° (narrow beam)
- 30° (RGBW wide)
- 108° (WW/CW flood)
- Illuminance: 26,750 lux @ 5m White LED: 1440W

COLOR & EFFECTS

- Color Temperature: 2700K – 10,000K (Adjustable)
- Dimming: 0–100% Linear Dimming
- Strobe: 1–25 Hz

CONTROL

- Control Protocols: DMX512 / RDM / Art-Net / sACN
- Channel Modes: 34CH / 61CH / 261CH / 307CH / 327CH / 12CH / 39CH / 61CH / 331CH / 340CH / 200CH / 240CH
- Pixel Mapping: Supported

PERFORMANCE

- Refresh Rate: Up to 25,000 Hz

DISPLAY

- TFT Screen

CONSTRUCTION

- Housing: Magnesium + Aluminum alloy
- Cooling: Passive system

ENVIRONMENTAL

- IP Rating: IP65
- Operating Temperature: -15°C to 45°C

PHYSICAL

- Dimensions: 1000 × 332 × 223 mm
- Weight: 35 kg
- Total Power: 1400W

HYDREX WASHFLOW FX 1650



ELECTRICAL

- Voltage: AC 100–240V, 50/60Hz
- Power Consumption: 900W

LIGHT SOURCE

- Main LEDs: 16 × 50W RGBW LEDs
- Auxiliary LEDs: 0.3W 5050 RGB LEDs
- LED Life: 50,000+ hours

OPTICS

- Zoom Angle: 4° – 60° linear zoom
- Color Mixing: RGBW uniform mixing system

EFFECTS

- Pixel control: Individual LED control
- Built-in FX: Rainbow, chase, flow effects
- Aura effect: Inner aperture control for flowing color effects
- Strobe: 1–30Hz
- Dimmer: 0–100% linear

MOVEMENT

- Pan: 540°
- Tilt: 270°
- High-speed motor with smooth positioning

CONTROL

- DMX Channels:
- Basic: 24CH
- Standard: 44CH
- Extended: 48CH / 113CH
- Protocols: DMX512, RDM, Art-Net
- Display: OLED Touch Screen

CONNECTIONS

- DMX: Waterproof 3-pin XLR in/out
- Power: Waterproof PowerCON in/out
- Network: Waterproof Art-Net in/out

CONSTRUCTION

- Housing: Die-cast aluminum
- Cooling: Intelligent temperature-controlled system
- Protection: Overheat protection

PHYSICAL

- IP Rating: IP65
- Dimensions: 392 × 283 × 511 mm
- Weight: 21 kg

COLORSHAFT Z10 ZOOM BAR



ELECTRICAL AND CONNECTORS

- Power Supply: AC 100V–240V, 50/60Hz
- Power Consumption: 1200W (maximum)
- Data Input/Output: 3-pin XLR socket

LIGHT SOURCE

- Beam Source: 10 × 60W RGBW LEDs
- Radiant Strobe: 200 × 4W Warm White/Cold White LEDs + 560 × 0.3W RGB LEDs
- Expected Lifespan: 20,000 hours
- White Light Temperature: 7500K

OPTICS

- Beam Angle: 3° – 45°

COLOR SYSTEM

- Advanced 4-colour RGBW mixing achieving high Colour Rendering Index (CRI)
- Uniform light beam with no colour shadows
- Rich saturated and pastel colour hues
- Dynamic colour macro effects with adjustable speed

DIMMER & STROBE

- Electronic dimmer for smooth adjustment from 0% to 100%
- White or colour strobe effects with speed adjustable from 1 to 25 flashes per second

MOVEMENT

- Moving-head operation via 8- or 16-bit resolution
- Tilt range: 240°

EFFECTS

- 2D and 3D graphical effect capabilities
- Effects compatible with beam, wash, or matrix applications
- Strobe effect with 40-section pixel control

CONTROL AND SOFTWARE

- Operating Modes: DMX512 / RDM / ArtNet
- Control Channel Modes: 32 / 243 channels

WORK ENVIRONMENT

- Operating Temperature: 0°C – 55°C
- Waterproof Rating: IP20

DIMENSIONS AND WEIGHT

- Size: 1015 × 175 × 377 mm
- Net Weight: 26 kg

CERTIFICATION

- Certifications: CSA Special Publication SPE-1000-21



Scan the QR code for more product details

STATIC WASH LIGHT



HEX-IP

- 7-HEX-IP
- 12-HEX-IP
- 18-HEX-IP
- PIXBAR HEX-1820 IP



ROAR SHOCKER PANEL FIX

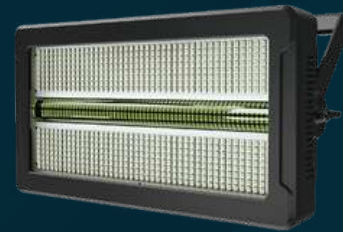

VIVID SERIES SHOCKER 2



PRO LINE 10 IP



T12 WASHBAR



PRO STORM BAR 11



AUORA BATTEN 12*IP



FLUX F16

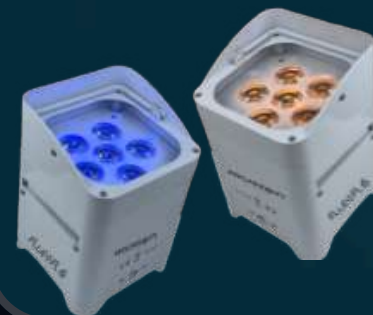

PIXEL TUBE



VIVID SERIES - 300W



aurorä

7-HEX-IP



7-HEX-IP

LIGHT SOURCE

- LED Type: 7 × 20W RGBWA+UV HEX LEDs
- Rated LED Lifespan: 50,000 hours
- CRI (Color Rendering Index): >90
- Color Mixing: RGBWA+UV, High Precision Blending
- Beam Angles: 6° / 10° / 15° / 24° / 36°
- Field Angle: 50° max
- Flicker-Free: Yes (Ideal for TV & Film)
- PWM Frequency: 16 kHz (eliminates flickering in cameras & filming)
- UV Wavelength: 395–400nm

OPTICAL SYSTEM & COLOR FEATURES

- Lens Type: Tempered glass with anti-reflective coating
- Color Macros: Yes, with custom & pre-built effects
- Dimming: 0–100% electronic dimming, smooth linear fade
- Dimming Curves: 4 selectable curves (Linear, Square, S-Curve, Dimmer)
- Strobe Speed: 1–25 flashes per second
- White Balance Correction: Yes, adjustable color temperature
- Saturation Control: Yes
- HSI Color Mixing Mode: Yes

CONSTRUCTION & ENVIRONMENTAL PROTECTION

- Housing Material: Die-cast aluminum with tempered glass front panel
- Cooling System: Fanless convection cooling (silent operation)
- Waterproof Rating: IP65 (Dustproof & Waterproof for outdoor use)
- Operating Temperature: -15°C to 55°C
- Storage Temperature: -25°C to 65°C
- Humidity Tolerance: 10% – 90% (non-condensing)
- Shock Resistance: Vibration-tested for road-ready durability

DIMENSIONS & WEIGHT

- Fixture Size: 250 × 240 × 190 mm
- Net Weight: 4.3 kg
- Bracket Type: Double yoke for floor standing & truss mounting

CONTROL & PROGRAMMING

- Control Protocols: DMX512 & RDM
- DMX Channel Modes: 6CH / 7CH / 8CH / 13CH
- User Interface: LCD display with 4-button touch panel
- Wireless Control: Optional via external DMX node
- Master/Slave Mode: Yes
- Standalone & Auto Mode: Yes
- Pre-Programmed Shows: Yes, with adjustable speed
- RDM Compatibility: Yes, for remote addressing & diagnostics
- Software Upgradeable: Yes, via DMX/RDM

POWER & CONNECTIVITY

- Input Voltage: 100–240V AC, 50/60Hz
- Power Consumption: 140W (max)
- Power Connectors: Seetronic Waterproof PowerCon in/out
- Control Data In/Out: Seetronic Waterproof 3-pin XLR DMX
- Power Factor: >0.98
- Standby Power Draw: <1W

COMPLIANCE & CERTIFICATIONS

- CE Certification
- LVD (2014/35/EU): Safety of electrical equipment supplied at low voltage
- EMC (2014/30/EU): Electromagnetic Compatibility
- RoHS (2011/65/EU): Restriction of hazardous substances
- CSA Certified (Canadian Standards Association – Safety & Performance Compliance for North America)
- Safety Features: Overheat protection, auto shutdown on failure
- Overvoltage Protection: Yes
- Short Circuit Protection: Yes

STATIC WASH LIGHT

12-HEX-IP

LIGHT SOURCE

- LED Type: 12 × 20W RGBWA+UV HEX LEDs
- Rated LED Lifespan: 50,000 hours
- CRI (Color Rendering Index): >90
- Color Mixing: RGBWA+UV, High Precision Blending
- Beam Angles: 6° / 10° / 15° / 24° / 36°
- Field Angle: 50° max
- Flicker-Free: Yes (Ideal for TV & Film)
- PWM Frequency: 16 kHz (eliminates flickering in cameras & filming)
- UV Wavelength: 395–400nm

OPTICAL SYSTEM & COLOR FEATURES

- Lens Type: Tempered glass with anti-reflective coating
- Color Macros: Yes, with custom & pre-built effects
- Dimming: 0–100% electronic dimming, smooth linear fade
- Dimming Curves: 4 selectable curves (Linear, Square, S-Curve, Dimmer)
- Strobe Speed: 1–25 flashes per second
- White Balance Correction: Yes, adjustable color temperature
- Saturation Control: Yes
- HSI Color Mixing Mode: Yes

CONSTRUCTION & ENVIRONMENTAL PROTECTION

- Housing Material: Die-cast aluminum with tempered glass front panel
- Cooling System: Fanless convection cooling (silent operation)
- Waterproof Rating: IP65 (Dustproof & Waterproof for outdoor use)
- Operating Temperature: -15°C to 55°C
- Storage Temperature: -25°C to 65°C
- Humidity Tolerance: 10% – 90% (non-condensing)
- Shock Resistance: Vibration-tested for road-ready durability

DIMENSIONS & WEIGHT

- Fixture Size: 263 × 259 × 168 mm
- Net Weight: 6.6 kg
- Bracket Type: Double yoke for floor standing & truss mounting

CONTROL & PROGRAMMING

- Control Protocols: DMX512 & RDM
- DMX Channel Modes: 6CH / 7CH / 8CH / 13CH
- User Interface: LCD display with 4-button touch panel
- Wireless Control: Optional via external DMX node
- Master/Slave Mode: Yes
- Standalone & Auto Mode: Yes
- Pre-Programmed Shows: Yes, with adjustable speed
- RDM Compatibility: Yes, for remote addressing & diagnostics
- Software Upgradeable: Yes, via DMX/RDM

POWER & CONNECTIVITY

- Input Voltage: 100–240V AC, 50/60Hz
- Power Consumption: 240W (max)
- Power Connectors: Seetronic Waterproof PowerCon in/out
- Control Data In/Out: Seetronic Waterproof 3-pin XLR DMX
- Power Factor: >0.98
- Standby Power Draw: <1W

COMPLIANCE & CERTIFICATIONS

- CE Certification
- LVD (2014/35/EU): Safety of electrical equipment supplied at low voltage
- EMC (2014/30/EU): Electromagnetic Compatibility
- RoHS (2011/65/EU): Restriction of hazardous substances
- CSA Certified (Canadian Standards Association – Safety & Performance Compliance for North America)
- Safety Features: Overheat protection, auto shutdown on failure
- Overvoltage Protection: Yes
- Short Circuit Protection: Yes

aurorä

12-HEX-IP



Scan the QR code for more product details

UPC# : 673324965098



Scan the QR code for more product details

UPC# : 673324965091

aurorä

18-HEX-IP

STATIC WASH LIGHT

18-HEX-IP



LIGHT SOURCE

- LED Type: 18 x 15W RGBWA+UV HEX LEDs
- Rated LED Lifespan: 50,000 hours
- CRI (Color Rendering Index): >90
- Color Mixing: RGBWA+UV, High Precision Blending
- Beam Angles: 6° / 10° / 15° / 24° / 36°
- Field Angle: 50° max
- Flicker-Free: Yes (Ideal for TV & Film)
- PWM Frequency: 16 kHz (eliminates flickering in cameras & filming)
- UV Wavelength: 395-400nm

OPTICAL SYSTEM & COLOR FEATURES

- Lens Type: Tempered glass with anti-reflective coating
- Color Macros: Yes, with custom & pre-built effects
- Dimming: 0-100% electronic dimming, smooth linear fade
- Dimming Curves: 4 selectable curves (Linear, Square, S-Curve, Dimmer)
- Strobe Speed: 1-25 flashes per second
- White Balance Correction: Yes, adjustable color temperature
- Saturation Control: Yes
- HSI Color Mixing Mode: Yes

CONSTRUCTION & ENVIRONMENTAL PROTECTION

- Housing Material: Die-cast aluminum with tempered glass front panel
- Cooling System: Fanless convection cooling (silent operation)
- Waterproof Rating: IP65 (Dustproof & Waterproof for outdoor use)
- Operating Temperature: -15°C to 55°C
- Storage Temperature: -25°C to 65°C
- Humidity Tolerance: 10% - 90% (non-condensing)
- Shock Resistance: Vibration-tested for road-ready durability

DIMENSIONS & WEIGHT

- Fixture Size: 263 x 259 x 168 mm
- Net Weight: 7 kg
- Bracket Type: Double yoke for floor standing & truss mounting

CONTROL & PROGRAMMING

- Control Protocols: DMX512 & RDM
- DMX Channel Modes: 6CH / 7CH / 8CH / 13CH
- User Interface: LCD display with 4-button touch panel
- Wireless Control: Optional via external DMX node
- Master/Slave Mode: Yes
- Standalone & Auto Mode: Yes
- Pre-Programmed Shows: Yes, with adjustable speed
- RDM Compatibility: Yes, for remote addressing & diagnostics
- Software Upgradeable: Yes, via DMX/RDM

POWER & CONNECTIVITY

- Input Voltage: 100-240V AC, 50/60Hz
- Power Consumption: 270W (max)
- Power Connectors: Seetronic Waterproof PowerCon in/out
- Control Data In/Out: Seetronic Waterproof 3-pin XLR DMX
- Power Factor: >0.98
- Standby Power Draw: <1W

COMPLIANCE & CERTIFICATIONS

- CE Certification
- LVD (2014/35/EU): Safety of electrical equipment supplied at low voltage
- EMC (2014/30/EU): Electromagnetic Compatibility
- RoHS (2011/65/EU): Restriction of hazardous substances
- CSA Certified: CSA Special Publication SPE-1000-21
- Safety Features: Overheat protection, auto shutdown on failure
- Overvoltage Protection: Yes
- Short Circuit Protection: Yes

PIXBAR HEX-1820 IP

LIGHT SOURCE

- LED Type 18 x 20W HEX LEDs (RGBWA+UV)
- LED Brand High-intensity professional-grade
- Total Power Output 360W max
- LED Lifetime 50,000 hours (average rated life)
- Color Mixing Red, Green, Blue, White, Amber, UV
- Refresh Rate ≥ 1200Hz (flicker-free for camera use)
- Beam Angle 25°
- Field Angle 35°
- Pixel Control 18 individual controllable pixels

OPTICAL SYSTEM & COLOR FEATURES

FEATURES

- Lens Type: Tempered glass with anti-reflective coating
- Color Macros: Yes, with custom & pre-built effects
- Dimming: 0-100% electronic dimming, smooth linear fade
- Dimming Curves: 4 selectable curves (Linear, Square, S-Curve, Dimmer)
- Strobe Speed: 1-25 flashes per second
- White Balance Correction: Yes, adjustable color temperature
- Saturation Control: Yes
- HSI Color Mixing Mode: Yes

DIMENSIONS & WEIGHT

- Housing Material Die-cast aluminum with anti-corrosion coating
- Finish Color Matte black
- Dimensions 1000 x 85 x 120 mm (39.4" x 3.3" x 4.7")
- Net Weight 6.2 kg (13.7 lbs)
- Mounting Options Dual adjustable brackets (included)

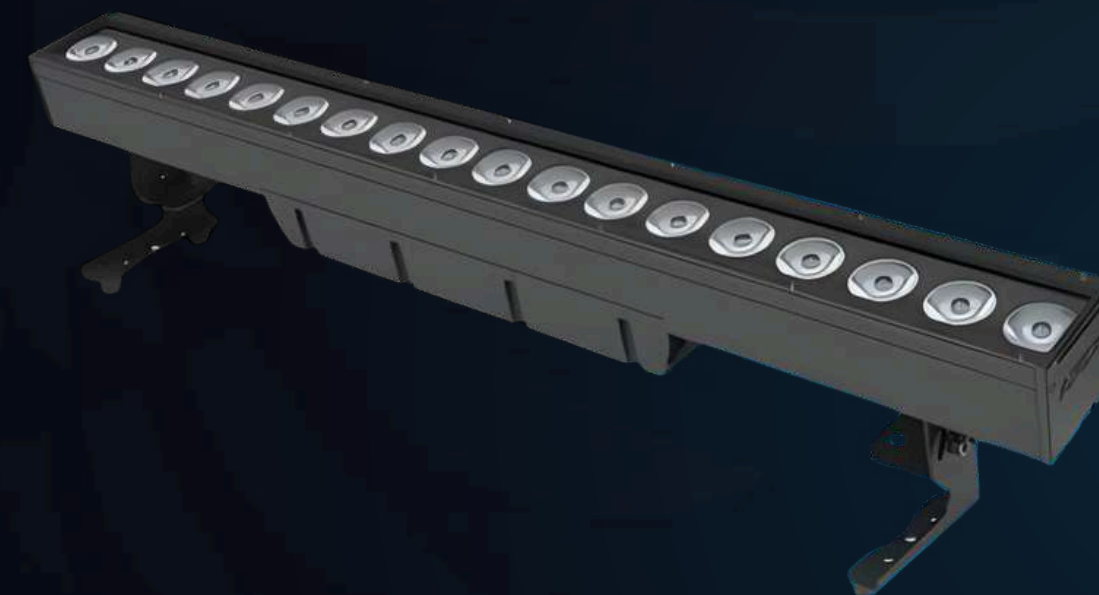

CONTROL & OPERATION

- Control Protocols DMX512, RDM
- DMX Channel Modes 8 / 12 / 36 / 108
- Display OLED screen with capacitive touch buttons
- Dimming 0-100% (16-bit resolution)
- Strobe Function 1-30Hz variable speed
- Built-in Programs Auto run, color fade, strobe, sound active
- DMX Connector Type 3-pin XLR or PG waterproof data ports
- Control Modes DMX, Manual, Auto, Sound, Slave

POWER & CONNECTIVITY

- Input Voltage 100-240V AC, 50/60Hz (auto-ranging)
- Power Consumption Max 360W
- Power Connector PowerCON or PG waterproof connector
- Power Linking Yes (Hand-in-hand via PG connectors)
- Fuse Rating T5A / 250V

COMPLIANCE & CERTIFICATIONS

- CE Certification
- LVD (2014/35/EU): Safety of electrical equipment supplied at low voltage
- EMC (2014/30/EU): Electromagnetic Compatibility
- RoHS (2011/65/EU): Restriction of hazardous substances
- CSA Special Publication SPE-1000-21
- Safety Features: Overheat protection, auto shutdown on failure
- Overvoltage Protection: Yes
- Short Circuit Protection: Yes

aurorä

PIXBAR HEX-1820 IP

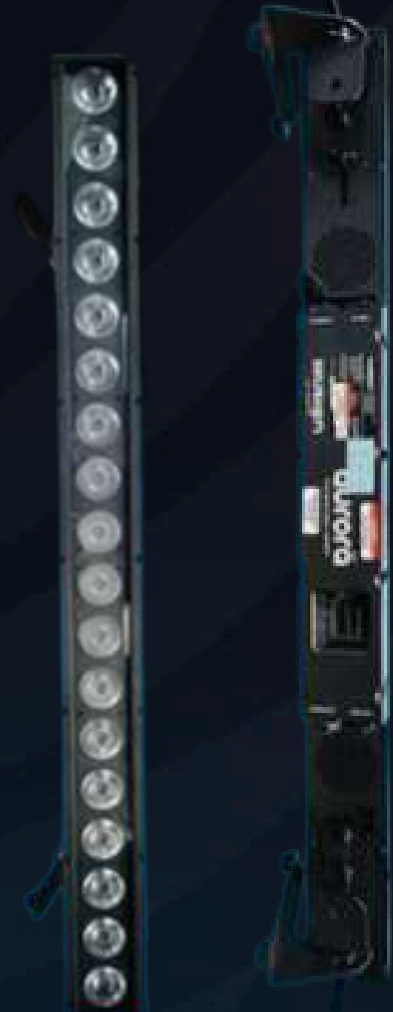

Scan the QR code for more product details

UPC# : 673324965074



Scan the QR code for more product details

UPC# : 602835339739

PRO-LINE 10 IP



ELECTRICAL AND CONNECTORS

- Voltage: AC 100V-240V, 50/60Hz
- Rated Power: 900W
- Data Input/Output: 3-pin XLR Socket or PG handheld waterproof plug
- Power Supply: PowerCon (PC) or PG waterproof plug

LIGHT SOURCE

- LEDs: 10 × 120W RGBWA LEDs
- Average Lifespan: 50,000 hours

DIMMING/STROBE

- Electronic dimmer: Linear dimming from 0% to 100%
- Strobe speed: 1-25 times per second

CONTROL

- Operating Mode: DMX512 / RDM
- Control Channel Mode: 14 / 55 CH
- Splicing: Quick splicing and quick locking

WORK ENVIRONMENT

- Maximum Ambient Temperature: +55 °C
- Minimum Operating Temperature: -10 °C
- Waterproof Grade: IP65

SIZE AND WEIGHT

- Dimensions: 100 × 94 × 114 mm (excluding bracket light groove)
- Net Weight: 13.6 kg

CERTIFICATIONS

- CE Certified
- RoHS Compliant



Scan the QR code for more product details



PRO-STORM BAR II



ELECTRICAL AND CONNECTORS

- Voltage: AC 100V-240V, 50/60Hz
- Rated Power: 650W
- Flash Power: 950W (max)
- Data Input/Output: 3-pin XLR Socket or PG handheld waterproof plug
- Power Supply: PowerCon (PC) or PG waterproof plug

LIGHT SOURCE

- LED: 224 × 4W CW (2-in-1) in the middle + 672 × 0.5W RGB (3-in-1) on both sides
- Average Lifespan: 50,000 hours

COLOUR

- Middle: White + Cool White color mixing
- Sides: RGB color mixing on both sides

DIMMING/STROBE

- Electronic dimmer: Linear dimming from 0% to 100%
- Strobe speed: 1-25 times per second

EFFECT

- Built-in chase effects, independent control for middle and side light sources

CONTROL AND SOFTWARE

- Operating Mode: DMX512, RDM, Art-Net
- Control Channel Modes: 8 / 16 / 22 / 40 / 113 / 18 / 34 / 66 / 69 / 118 / 71 CH
- User Interface: Convenient touch LCD

WORK ENVIRONMENT

- Maximum Ambient Temperature: +55 °C
- Minimum Operating Temperature: -15 °C
- Waterproof Grade: IP65

SIZE AND WEIGHT

- Dimensions: 1000 × 95 × 200 mm (excluding bracket light groove)
- Net Weight: 9.7 kg

CERTIFICATIONS

- CE Certified
- RoHS Compliant
- CSA Special Publication SPE-1000-21



Scan the QR code for more product details



PIXEL TUBE

SPECIFICATIONS

- Input Voltage & Frequency: 100-240VAC, 50/60Hz
- Light Source: 192 pcs × 0.2W
- Power Consumption: 39W
- Color System: RGBWA color mixing
- Maximum Running Time (full light/monochrome): 1.5 hours - 12 hours (mode optional)
- Maximum Runtime (monochromatic bright): Up to 12-13 hours
- Charging Time: 3 hours
- Dimming: 4 dimming modes
- Control Mode: Wireless DMX / Phone app / Remote control / Master-slave mode / Phone app control
- Channel: 4CH / 5CH / 6CH / 7CH / 12CH / 40CH / 80CH / 160CH
- Display: OLED display
- Power Connection: Adapter for charging
- Signal Connection: 2.4G wireless connection, effective within range
- Battery: Lithium electronic battery, 9600mAh
- Shell Material: Aluminum alloy + acrylic
- Standard Accessories: Infrared remote control, charger
- Size: 1500mm (length) × 55mm (diameter)
- Weight: 2.0 kg
- Certification: ETL, CE, RoHS & CSA Special Publication SPE-1000-21



Scan the QR code for more product details

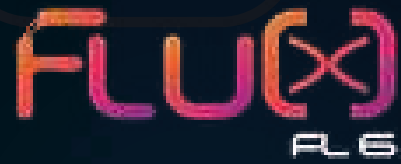

FLUX FL6



SPECIFICATIONS

- Power supply: AC100V-250V
- Frequency: 50-60Hz
- Power consumption: 90W
- Li-ion Battery: 9600mAh
- Light source: 6pcs 15W high brightness RGBWAUV 6-in-1 LEDs
- Lamp life: 60,000-100,000 hrs (6-10 ten thousand hrs)
- LED angle: 30° (±5°)
- Color: 16.7 million kinds of color change
- Control channels: 6 / 10 channels
- Battery power & wireless DMX & IR
- Built-in 2.4G receiver / transmitter for wireless DMX operations
- Control mode: DMX512, WiFi, master/slave, auto, sound active
- Automatic modes (by function button):
 - Color change
 - Color strobe
 - Color dimmer
 - Color gradual change
 - Color jump change
- Operation menu: 4-digit digital LCD display
- Packing size: 232220 cm
- Net Weight (N.W.): 2.50 kg
- Gross Weight (G.W.): 3.0 kg
- Certification: ETL, CE, RoHS, CSA Special Publication SPE-1000-21



Scan the QR code for more product details

VIVID SERIES

E-300WW

VIVID SERIES - E-300WW



SPECIFICATIONS

- Power supply: AC100V-240V, 50Hz/60Hz
- Power consumption: 350W
- Lamp: COB LED 300W, white
- Lux: 37,800 lm - 41,000 lm
- Lifetime of LED: More than 50,000 hours
- Color temperature: 3200K and 5600K are available
- CRI: >90Ra
- Dimmer: 0-100% linear dimmer
- Beam angle: 19° / 26° / 36° / 50°
- Strobe: 1-20 flash per second
- Heat dissipation: High quality radiator, low noise fan, LED display
- Control mode: International standard DMX512 signal, with XLR 3PIN or XLR 5PIN connectors
- Channel mode: 1 channel mode and 2 channels mode
- Protection grade: IP20
- Use environment temperature: -20°C - 45°C
- Net Weight (N.W.): 10.5 kgs
- Gross Weight (G.W.): 13.8 kgs
- Dimensions (LxWxH): 770 x 330 x 340 mm
- Certifications: CSA Special Publication SPE-1000-21

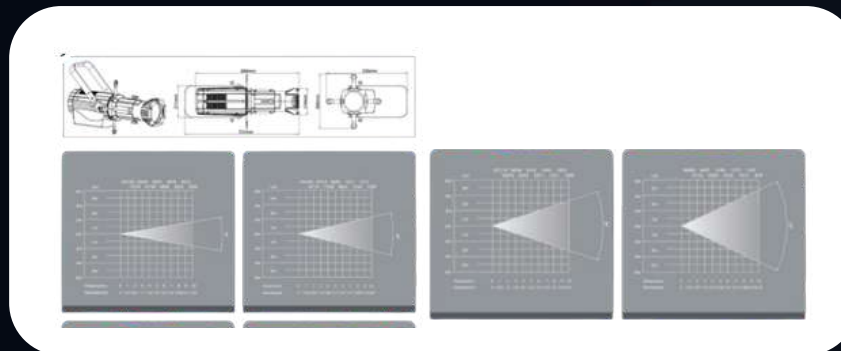

Scan the QR code for more product details



Aurora Batten 12X IP

AURORA BATTEN 12X IP



LIGHT SOURCE

- Light Source: 12 Pcs 10W RGBW LED
- Output: >7800LM (peak value)
- Illuminance: 4180 Lux @ 5m (8°)
- Color Temperature: 2400K-8500K
- LED Lifespan: 50K hrs
- Beam Angle: 8° / 15° / 25° / 45° Optional
- CRI: Ra > 80
- Photochromic:
 - R: 625±3NM
 - G: 525±3NM
 - B: 455±3NM
 - W: 3000K±100K

EFFECT

- Color gamut: RGBW / CMY2-colorspace mode
- Strobe: Unique pulse mode
- Dimmer: 4 dimming curves, 0-100% dimming

CONTROL & PROGRAM

- Control mode: DMX512 / RDM
- DMX Channel: 4CH / 7CH / 8CH
- Display value: Nixie tube

POWER/SIGNAL CONNECTION

- Mains: 100-240VAC, 50/60Hz
- Power connection: PowerCon In/Out
- Data connections: IP65 3-pin XLR In/Out for DMX
- Consumption: Power 120W
- Power Factor: >0.95
- Ambient: -20°C ~ +45°C

PHYSICAL

- Dimensions: 1000 x 100 x 64 mm
- Weight: 3.7 KG
- Cooling: Low noise fan
- Housing: Aluminium-magnesium alloy, hot paint
- IP rating: IP65
- Accessories: Power Cable, Omega Bracket

MODELS

- PL-R120

CERTIFICATION

- CSA Special Publication SPE-1000-21



Scan the QR code for more product details

VIVID SERIES

SHOCKER 2

VIVID SERIES SHOCKER 2



Total power 200W	Channel 2/6CH	weight 2.6KG
----------------------------	-------------------------	------------------------

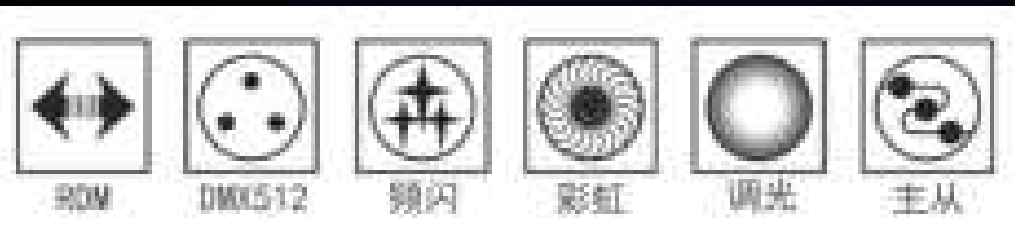

POWER SUPPLY

- Input Voltage: AC 100V-240V, 50/60Hz
- Power Consumption: 200W

LIGHT SOURCE

- LED: 36 × 10W LEDs
- Rated Life: 50,000 hours
- Color Temperature: 2800K-6500K (adjustable)

OPTICS

- Beam Angle: 38°
- Dimmer: 0-100% full range dimming

CONTROL

- Operation Modes: DMX512 / RDM
- Control Channel Mode: 2/6 channels

DISPLAY

- Advanced and convenient full-color LCD
- Can be rotated 180° to fit different installation positions

FEATURES

- Strobe: 1-20 Hz
- Cooling System: Fan cooling
- Working Environment: -5°C ~ 45°C

SIZE AND WEIGHT

- Dimensions: 258 × 218 × 196 mm
- Net Weight: 2.6 kg

CERTIFICATION

- CSA Special Publication SPE-1000-21



Scan the QR code for more product details

ROAR

SHOCKER PANEL FX

ROAR SHOCKER PANEL FX

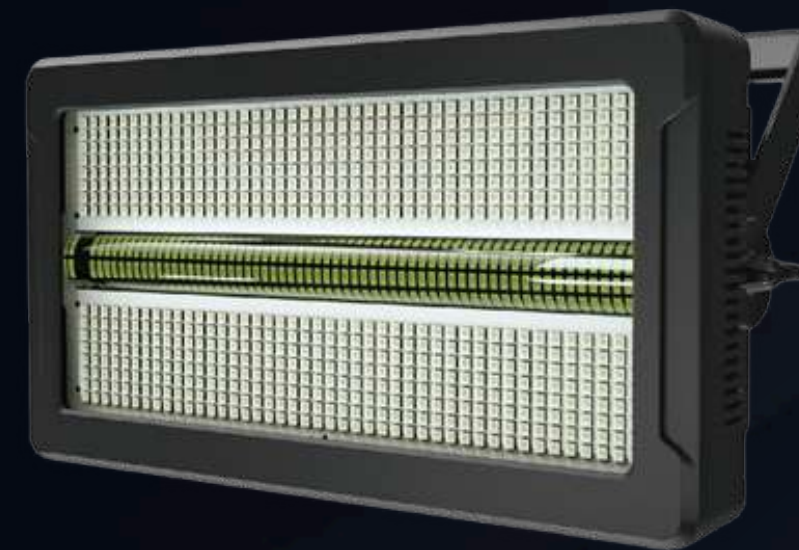

Total power 800W	Channel 6/16/30 CH	weight 4.35kg
----------------------------	------------------------------	-------------------------



POWER SUPPLY

- Input Voltage: AC100V-240V, 50/60Hz
- Power Consumption: 900W (Max 1650W)

LIGHT SOURCE

- LEDs: 192 pcs 0.5W RGB LEDs + 240 pcs 3W White LEDs
- Rated Life: 50,000 hours
- Color: RGB + Mix White

FEATURES

- Control Modes: DMX512 / RDM
- Channel Modes: 6 / 16 / 30 channels
- Dimmer: 0-100% full range dimming
- Effects: RGB 6 sections + White 6 sections pixel control, aura color, and pattern

DISPLAY

- Advanced and convenient full-color LCD
- Can be rotated 180° for flexible installation

SPECIFICATIONS

- Strobe: 0-20Hz
- Angle: 0-90°
- Mode: RGB + White
- IP Rating: IP20
- Working Temperature: -5°C ~ 45°C
- Dimensions: 380 × 420 × 123 mm
- Net Weight: 4.35 kg

CERTIFICATION

- CSA Special Publication SPE-1000-21



Scan the QR code for more product details

T12 WASHBAR



LIGHT SOURCE

- 12x 9W (3W each color) Tri-color RGB (3 groups of 4 LEDs)

BEAM ANGLE

- 42°

POWER CONSUMPTION

- 36W

VOLTAGE

- AC 100–240V, 50/60Hz

DIMENSIONS

- 1000 x 51 x 157 mm

WEIGHT

- 2.8 kg

DMX CHANNELS

- 3 / 5 / 13 CH

CONTROL MODES

- DMX, Auto, Sound, Static, Manual, IR Remote

HOUSING

- Durable Metal

COOLING

- Passive

MOUNTING

- Multi-angle bracket

CERTIFICATION

- CSA Special Publication SPE-1000-21



Scan the QR code for
more product details

ATMOSPHERIC



FOG MACHINE

- Z-1520 RGB



HAZE MACHINE

- M-7X
- Z-350 FAZER
- HZ-100
- F-2 FAZER MACHINE
- F-6 FAZER
- F-7X SMAZE



LOW LYING FOG

- LOW FOG
- LED CO₂ GUN
- CO₂ GUN
- LED CO₂ JET
- LOW FOG PRO



SPARKULAR & COLD SPARX

- SPARX PRO
- SPARX FALL
- SPARX MINI
- SPARX SPIN
- SPARX PORTABLE POWER
- SPARX COMPOSITE
- SPARX MOTO M3



JET EFFECTS

- CO₂ JET SF-C24

FOG MACHINE

Z-1520 RGB



SPECIFICATION

- Rated Voltage US Model: AC 100–120V, 50/60Hz, 13.5A
- EU Model: AC 220–240V, 50/60Hz, 7A
- Rated Power: 1516W
- Light Source: 22 x 3W RGB LEDs (8 Red, 7 Green, 7 Blue)
- Warm-Up Time: Approximately 5 minutes
- Fluid Consumption: 150 ml/min at 100% output
- Fluid Tank Capacity: 2.4 Liters (0.63 gallon)
- Compatible Fluid: FLC Super Light Fog Fluid
- Ambient Temp. Range: 0°C – 40°C (32°F – 104°F)
- Output Height: Up to 6 meters
- Control Methods: Manual, Timer, DMX 512, Master/Slave, Wireless
- DMX Channels: 8
- Connections: Neutrik Powercon (Power), XLR 3-pin and 5-pin (DMX)
- Dimensions: (L x W x H) 418 x 295 x 210 mm
- Weight: 10.4 kg (22.93 lbs)
- Certification: CSA Special Publication SPE-1000-21



Scan the QR code for more product details

JET EFFECTS

CO₂ JET SF-C24



SPECIFICATION

- Manufacturer: ILLUSION UNIVERSE
- Input Voltage & Frequency: AC 100–120V, 60Hz/ AC 200–240V, 50Hz
- Power Consumption: 24W
- Max Height of Gas Column: 10–12 meters
- Adjustable Angle: 0–180°
- Net Weight: 7.7 kg
- Gross Weight (1 Unit Flight Case): 10 kg
- Machine Dimensions: 275 x 194 x 200 mm
- Packing Dimensions: 380 x 380 x 320 mm
- Gas Consumption: High-purity CO₂
- Certification: CSA Special Publication SPE-1000-21



Scan the QR code for more product details

HAZE MACHINES

M-7X RGBA

SPECIFICATION

- Rated Voltage US model: AC 100–120V, 50/60Hz, 13A
 EU model: AC 220–240V, 50/60Hz, 6.5A
- Rated Power: 1516W
- Light Source: 22 × 3W RGBA LEDs (Red, Green, Blue, Amber)
- Warm Up Time: Approx. 7 minutes
- Fluid Consumption: 200 ml/min
- Fluid Tank Capacity: 2.4 Liters (0.63 gallon)
- Compatible Fluid: FLC Fog Fluid
- Ambient Temp. Range: 0°C – 40°C (32°F – 104°F)
- Output: Fog reaches up to 10 meters in height
- Control: Manual, Timer, DMX512, Master/Slave, Wireless DMX (Optional)
- DMX Channels: 9
- Connections:
- Neutrik TRUE 1 Connector (Power)
- XLR 3-pin & 5-pin (DMX)
- Included Accessories: W-2 Wireless Radio Transmitter
- Optional Accessories:
- WTR-90 Wireless DMX
- W-DMX-PCB ×1
- W-DMX-XLR ×1
- Dimensions: 436 × 193 × 383 mm (L17.2 × W 7.6 × H 15 in.)
- Weight: 14 kg (30.8 lbs)
- Certification: CSA Special Publication SPE-1000-21



Scan the QR code for more product details

Z-350 FAZER

SPECIFICATION

- Rated Voltage:
- US model: AC 100–120V, 50/60Hz, 6A
- EU model: AC 220–240V, 50/60Hz, 3.15A
- Rated Power:
- AC 100–120V: Approx. 700W
- AC 220–240V: Approx. 750W
- Warm-Up Time: Approx. 4.5 minutes
- Fluid Consumption: 3 ml/min (at 100% output)
- Fluid Tank Capacity: 1.3 Liters
- Compatible Fluid: FLG / FLH Haze Fluid
- Ambient Temp. Range: 0°C – 40°C (32°F – 104°F)
- Control Options: Manual, DMX-512
- DMX Channels: 2
- Connections:
- IEC (Power)
- XLR 3-pin (DMX)
- Optional Accessories: Z-3 Cable Remote
- Flight Case FZ-350
- Flight Case FX-4
- Dimensions: L 320 × W 153 × H 391 mm (12.60 × 6.02 × 15.39 in.)
- Weight: 8.5 kg (18.7 lbs)
- Certification: CSA Special Publication SPE-1000-21



Scan the QR code for more product details

HZ-100

SPECIFICATION

- Rated Voltage US model: AC 100–120V, 50/60Hz, 3.5A
- Rated Voltage EU model: AC 220–240V, 50/60Hz, 2.0A
- Rated Power: 390W
- Fluid Consumption: 0.7 ml/min
- Fluid Tank Capacity: 2.5 Liters (0.66 gallon)
- Compatible Fluid: HZL Fluid
- Operating Time: 60 hours at maximum continuous output
- Ambient Temperature Range: 0°C – 40°C (32°F – 104°F)
- Control: Manual; Timer (Optional); Wireless (Optional)
- Connections: IEC (Power)
- Optional Accessories: HC-1 Cable Timer Remote; HCR-1 Wireless Remote
- Dimensions: L 490 × W 250 × H 294 mm (L 19.30 × W 9.84 × H 11.57 inch)
- Weight: 13.2 kg (29.1 lbs)
- Certification: CSA Special Publication SPE-1000-21



Scan the QR code for more product details

HAZE MACHINES

F-2 FAZER MACHINE

SPECIFICATION

- Rated Voltage US Model: AC 100-120V, 50/60Hz, 8.5A
- Rated Voltage EU Model: AC 220-240V, 50/60Hz, 6.5A
- Rated Power: 1000W (120V) / 1450W (240V)
- Warm-Up Time: Approx. 1.5 minutes
- Fluid Consumption: 6.5 ml/min
- Fluid Tank Capacity: 5 Liters (≈ 1.32 gallons)
- Compatible Fluid: FLG-5E / FLH-5E Heavy Fog Fluids
- Operating Time: Up to ~12 hours at continuous max output
- Ambient Temp Range: 0°C – 40°C (32°F – 104°F)
- Control Methods: Manual, DMX512, Timer
- DMX Channels: 2
- Connection Interface: XLR 3-pin & 5-pin (for DMX in/out)
- Dimensions: L 399 × W 444 × H 268 mm (approx. 15.7 × 17.5 × 10.6 in)
- Weight: 14.7 kg (≈ 32.4 lbs)
- Certification: CSA Special Publication SPE-1000-21



Scan the QR code for more product details

F-6 FAZER

SPECIFICATION

- Rated Voltage
- US Model: AC 100 – 120V, 50 / 60 Hz, 12.5A
- EU Model: AC 220 – 240V, 50 / 60 Hz, 6.3A
- Rated Power: 1450 W
- Warm-Up Time: 1 minute (approx.)
- Fluid Consumption: 12 ml/min (at 100% output)
- Fluid Tank Capacity: 5 Liters (1.32 gallon)
- Compatible Fluid: FLG-5E
- Operating Time: 7 hours at max. output
- Ambient Temperature Range: 0°C – 40°C (32°F – 104°F)
- Control Methods: Manual, DMX 512, Timer, Wireless DMX (Optional)
- DMX Channels: 2 Channels
- Connection:
- Neutrik powerCon (Power)
- XLR 5-pin (DMX)
- Included Accessories: N/A
- Optional Accessories: ES-W-DMX Wireless, WTR-110 Wireless
- Dimensions:
- 493 mm (L) × 424 mm (H) × 280 mm (W)
- 19.4 in (L) × 16.69 in (H) × 10.59 in (W)
- Weight: 17.2 kg (37.80 lbs)
- Certification: CSA Special Publication SPE-1000-21



Scan the QR code for more product details

F-7X SMAZE

SPECIFICATION

- Rated Voltage:
- US Model: AC 100-120V, 50/60Hz, 13.5A
- EU Model: AC 220-240V, 50/60Hz, 8.0A
- Rated Power:
- 100V: 1400W
- 120V: 1600W
- 240V: 1900W
- Warm-Up Time: 8 minutes
- Fluid Consumption:
- Fog Mode: 150 ml/min (100% output)
- Faze Mode: 28 ml/min (100% output)
- Operating Time (Faze Mode): 2.8 hours at maximum output
- Fluid Tank Capacity: 5 liters x 2 tanks
- Compatible Fluids: FLG-5E, FLH-5E, FLZ-5E
- Ambient Temperature Range: 0°C – 40°C (32°F – 104°F)
- Control Methods: Manual, Timer, DMX 512, Wireless (Optional), W-DMX (Optional)
- DMX Channels: 3
- Interface:
- Neutrik power CON Connector (Power)
- XLR 3-pin and 5-pin Connector (DMX)
- Dimensions (L x W x H): 728 x 428 x 719 mm
- Weight: 53.0 kg (115.7 lbs)
- Certification: CSA Special Publication SPE-1000-21



Scan the QR code for more product details

SFX LOWFOG

SPECIFICATIONS

- Product Name: SFX LOWFOG
- Spray Height: 50-100 m²
- Voltage: AC110V ~220V, 60Hz / 50Hz
- Max Power: 220V 3500W / 110V 2000W
- Control: Manual
- DMX Channel: ---
- Heat-up time: 3500W (15-19 mins) / 2000W (20-25 mins)
- N.W.: 8.8 KG
- G.W.: 11.2 KG
- Product Size: 49 × 45 × 46.5 cm
- Packing Size (Carton): 49 × 45 × 46.5 cm
- Component: Power Cord
- Packing Option: Normal Carton / Flycase (Optional with higher cost)
- Coverage: 50-100 m²
- Certification: CSA Special Publication SPE-1000-21



SFX LED CO2 GUN

SPECIFICATIONS

- Spray Height: 6-8 Meter
- Angle: Forward Only
- Voltage: Powered By Battery
- Max Power: None
- Control: Manual
- DMX Channel: None
- Max Pressure: 1600 Psi
- N.W.: 3.5 KG
- G.W.: 5 KG
- Product Size: 69.5 × 10 × 20.5 cm
- Packing Size (Carton): 76 × 30 × 16 cm
- Component: High Pressure Hose 3 Meter
- Packing Option: Normal Carton / Flycase (Separate Cost)
- Certification: CSA Special Publication SPE-1000-21



SFX CO2 GUN

SPECIFICATIONS

- Spray Height: 6-8 Meter
- Angle: Forward Only
- Voltage: None
- Max Power: None
- Control: Manual
- DMX Channel: None
- Max Pressure: 1600 Psi
- N.W.: 1.5 KG
- G.W.: 3 KG
- Product Size: 48 × 6 × 20 cm
- Packing Size (Carton): 68 × 28 × 12 cm
- Component: High Pressure Hose 3 Meter
- Packing Option: Normal Carton
- Certification: CSA Special Publication SPE-1000-21



SFX LED CO2 JET

SPECIFICATIONS

- Spray Height: 8-10 Meter
- Angle: 0-90 degree adjustable
- Voltage: 100V - 240V / AC, 50/60 Hz
- Max Power: 150W
- Control: DMX512
- DMX Channel: 6
- Max Pressure: 1600 Psi
- N.W.: 5.2 KG
- G.W.: 8 KG
- Product Size: 20 × 27 × 39 cm
- Packing Size (Carton): 30 × 30 × 42 cm
- Component: Power Cord, DMX Cord, High Pressure Hose 6 Meter
- Packing Option: Normal Carton / Flycase (Separate Cost)
- Certification: CSA Special Publication SPE-1000-21



SFX LOWFOG PRO

SPECIFICATIONS

- Product Name: SFX LOWFOG
- Spray Height: 50-100 m²
- Voltage: AC110V ~220V, 60Hz / 50Hz
- Max Power: 220V 3500W / 110V 2000W
- Control: Manual
- DMX Channel: ---
- Heat-up time: 3500W (15-19 mins) / 2000W (20-25 mins)
- N.W.: 8.8 KG
- G.W.: 11.2 KG
- Product Size: 49 × 45 × 46.5 cm
- Packing Size (Carton): 49 × 45 × 46.5 cm
- Component: Power Cord
- Packing Option: Normal Carton / Flycase (Optional with higher cost)
- Coverage: 50-100 m²
- Certification: CSA Special Publication SPE-1000-21



Scan the QR code for more product details

SPARX PRO

SPECIFICATIONS

- MODEL NAME : SPARX PRO
- MODEL CODE : M-01
- DIMENSION: 230x195x300mm
- NET WEIGHT: 8.5kg
- VOLTAGE: 110V, 50/60Hz
- WORK POWER: 750W 6.8A
- FUSE : 110/10A
- EFFECT HEIGHT: 1-5m adjustable
- ALLOWABLE POWER CASCADE : 6 PCS
- INTERFACE: 3-pin XL, POWER IN/OUT
- CONTROL: DMX 2 channels, Wireless Remote
- Certification: CSA Special Publication SPE-1000-21



Scan the QR code for more product details

SPARX FALL

SPECIFICATIONS

- MODEL NAME : SPARX FALL
- MODEL CODE : M-03
- DIMENSION: 205x205x190mm
- NET WEIGHT: 6.3 KG
- VOLTAGE: 110V, 50/60Hz
- WORK POWER: 650W 6.0A
- FUSE : 110/10A
- EFFECT HEIGHT: 1-5m adjustable
- ALLOWABLE POWER CASCADE : 6 PCS
- INTERFACE: 3-pin XL, POWER IN/OUT
- CONTROL: DMX 2 channels, Wireless Remote
- CASING MATERIAL : ALUMINIUM
- Certification: CSA Special Publication SPE-1000-21



Scan the QR code for more product details

SPARX MINI

SPECIFICATIONS

- MODEL NAME : SPARX MINI
- MODEL CODE : M-04
- DIMENSION: 185x185x252mm
- NET WEIGHT: 5.9 KG
- VOLTAGE: 110V, 50/60Hz
- WORK POWER: 650W 6.0A
- FUSE : 110/10A
- EFFECT HEIGHT: 1-5m adjustable
- ALLOWABLE POWER CASCADE : 6 PCS
- INTERFACE: 3-pin XL, POWER IN/OUT
- CONTROL: DMX 2 channels, Wireless Remote
- CASING MATERIAL : ALUMINIUM
- Certification: CSA Special Publication SPE-1000-21



Scan the QR code for more product details

SPARX SPIN

SPECIFICATIONS

- MODEL NAME : SPARX SPIN
- MODEL CODE : M-02
- DIMENSION: 385x385x400mm
- NET WEIGHT: 20 KG
- VOLTAGE: 110V, 50/60Hz
- WORK POWER: 1350W 16.0A
- FUSE : 110/10A
- EFFECT HEIGHT: 1-5m adjustable
- ALLOWABLE POWER CASCADE : 2 PCS
- INTERFACE: 3-pin XL, POWER IN/OUT
- CONTROL: DMX 2 / 4 channels, Wireless Remote
- CASING MATERIAL : ALUMINIUM
- Certification: CSA Special Publication SPE-1000-21



Scan the QR code for more product details

PORTABLE POWER

SPECIFICATIONS

- MODEL NAME : SPARX PORTABLE POWER
- MODEL CODE : M-05
- DIMENSION: 270x270x136mm
- NET WEIGHT: 5.7 KG
- VOLTAGE: 110V, 50/60Hz
- BATTERY CAPACITY: 24V15A
- POWER : 900W
- CASING MATERIAL : ALUMINUM
- POWER IN/OUT
- Certification: CSA Special Publication SPE-1000-21



Scan the QR code for more product details

SPARK MOTO M3

SPECIFICATIONS

- Voltage : AC 100-240V, 50/60Hz
- Input Voltage : 32V
- Power Consumption : 450W
- DMX : 3PIN
- Machine Size : 220 x 240 x 285 mm (L x W x H)
- Carton Size : 290 x 290 x 380 mm (L x W x H)
- Net Weight : (NW)12 kg (26.5 lbs)
- Charging Time : 2 hours
- Battery Working Time : 1.5 hours
- Standby Time : 24 hours
- Effect Height : 2 - 5 meters
- Hopper Capacity : 150 grams
- Certification: CSA Special Publication SPE-1000-21

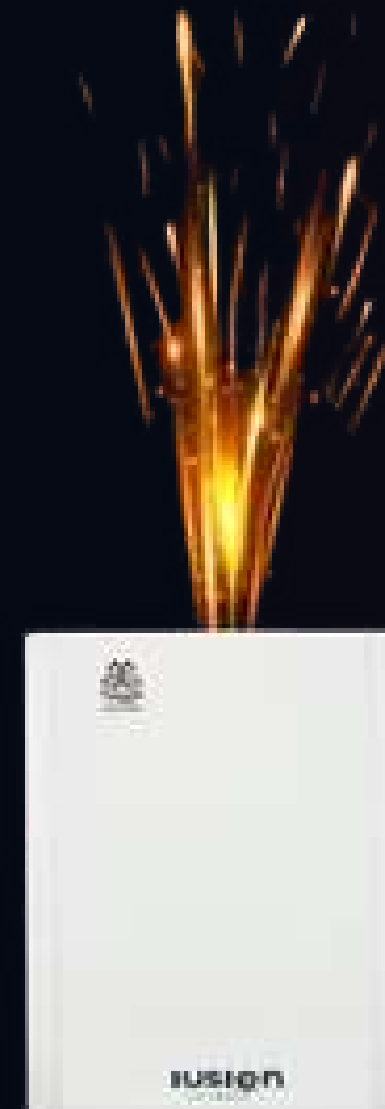

Scan the QR code for more product details

COMPOSITE TI

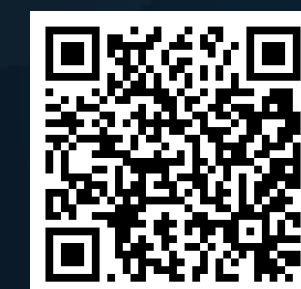

Scan the QR code for more product details



LED VIDEO WALL



DWS SERIES

- POSTER PLUS
- TOTEM POSTER



M SERIES

- INDOOR
- OUTDOOR - 3.9
- OUTDOOR - 2.9



SMART FAST FOLD SCREEN



FLEXNOVA P15

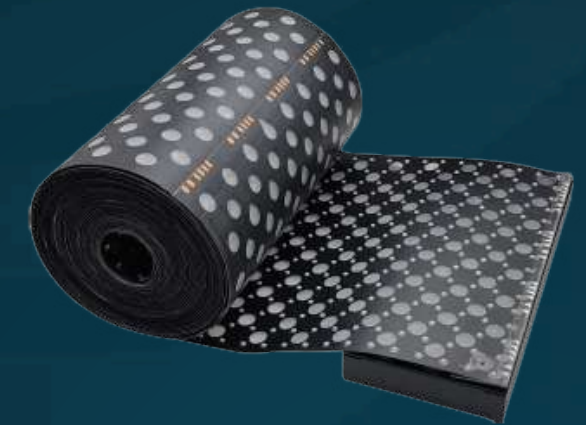



DWS POSTER PLUS



SPECIFICATIONS

- Brand: Illusion Universe
- Series: DWS Series
- Model: DWS POSTER PLUS
- Display Type: Indoor Full-Color LED Display
- Pixel Pitch: P3mm
- Viewing Angle (H/V): 140° / 140°
- Brightness: 1000 nits (Indoor) | 4500 nits (Outdoor)
- Minimum Viewing Distance: 3m (9.8ft)
- Refresh Rate: 3840Hz
- Media Compatibility: BMP, JPG, PNG, MP4, MPEG, MOV, AVI, 3GP
- Control Method: WiFi & USB
- Input Voltage: 100-240V AC, 50/60Hz (Auto-Ranging)
- Installation: Hanging / Standalone
- Waterproof Level: IP30
- Dimensions: 640mm x 960mm
- Weight: 13 KG (28.66 lbs)
- Certification: CSA Special Publication SPE-1000-21

TOTEM POSTER



DISPLAY SPECIFICATIONS

- Pixel Pitch: 2.5 mm
- LED Type: SMD2121 (3-in-1)
- Panel Resolution: 256 x 768 pixels
- Brightness: 800 NITS (calibrated), >1000 NITS (maximum)
- Refresh Rate: 3840 Hz
- Viewing Angle: 140° horizontal / 140° vertical
- Minimum Viewing Distance: 2.5 meters (8.2 feet)
- Color Temperature: 6500K
- Scan Mode : 1/32

GOB TECHNOLOGY

- Protection: GOB technology provides a protective resin layer over the LED modules
- Advantages: Enhanced durability, impact resistance, dustproof, and moisture-resistant
- Ideal Use Cases: High-traffic indoor environments such as showrooms, lobbies, and event venues

MECHANICAL SPECIFICATIONS

- Panel Dimensions: 640 mm x 2082 mm (25.2 in x 81.97 in)
- Weight: 65 kg (143.3 lbs)
- Housing Material: Iron SPCC
- LED Module Material: Glass-filled polycarbonate
- Mounting Options: Freestanding with optional casters; wall-mounted or suspended installations available
- Threaded Bolt: M10, 1.5

ELECTRICAL SPECIFICATIONS

- Input Voltage: 100-240 VAC, 50/60 Hz (auto-ranging)
- Power Consumption:
 - Maximum: 480W
 - Average: 144W
- Power Linking: Up to 4 units @ 120V
- Receiver Card: Novastar TB40
- Scan Mode: 1/32

CASCADING & CONNECTIVITY

- Cascading Capability: Connect up to 8 totems side-by-side
- Total Seamless Width: 5.12 meters (16.8 feet)
- Connectivity: Wi-Fi, Ethernet, USB, HDMI input
- Control System: Integrated media player with scheduling; compatible with iOS, Android, and PC
- Software Features: Remote monitoring, diagnostics, and content management GitLab

CERTIFICATIONS & COMPLIANCE

- CSA Certified: CSA Special Publication SPE-1000-21
- Operating Temperature: -10°C to 50°C
- Humidity Range: 10% to 90% RH
- Ingress Protection: IP40 (front), suitable for indoor use.

APPLICATIONS

- Retail Environments: Product promotions, digital signage
- Automotive Showrooms: Vehicle showcases, interactive displays
- Wedding Venues: Welcome messages, photo slideshows
- Corporate Events: Presentations, branding
- Exhibitions & Trade Shows: Dynamic content display, information kiosks



Scan the QR code for more product details

UPC# : 60283533948



Scan the QR code for more product details

UPC# : 673324965180

LED VIDEO WALL

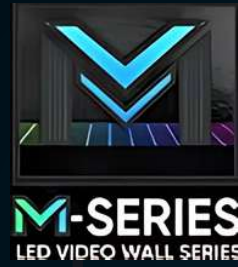

M-2.6 INDOOR

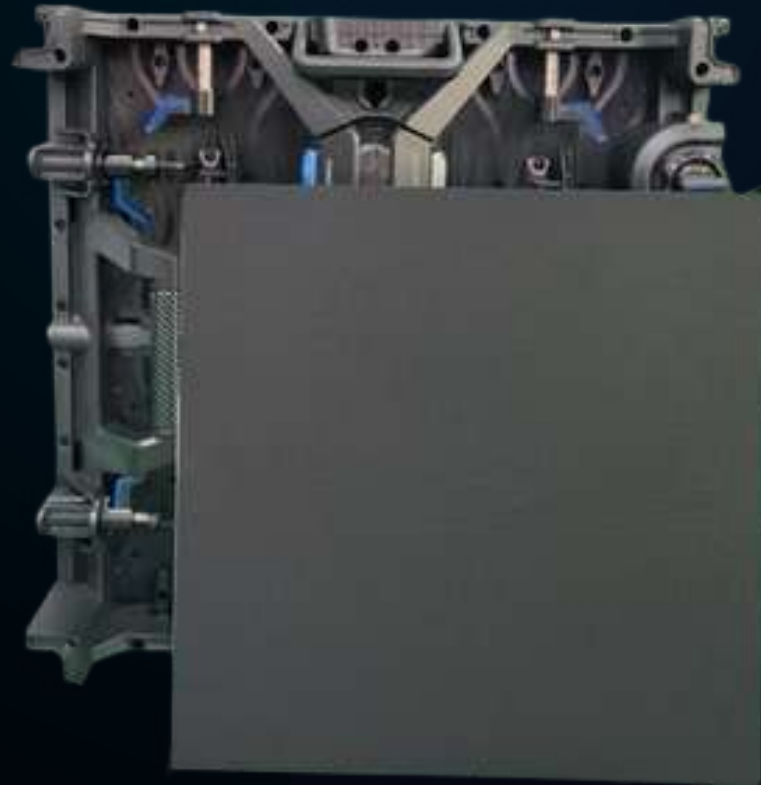

LED PERFORMANCE

- Pixel Pitch : 2.6 mm
- LED Type : High-contrast SMD, Leading Brand
- LED Configuration : 3-in-1 SMD
- Module Resolution : 96 x 96 pixels
- Panel Resolution : 192 x 192 pixels
- Brightness (Calibrated) : 1,000 NITS
- Brightness (Max) : >1,200 NITS
- Contrast Ratio : High dynamic contrast
- Refresh Rate : 7,680 Hz
- Gray Scale Processing :16-bit
- Scan Mode : 1/24 Constant Current
- Viewing Angle : (H/V)140° / 140°
- Minimum Viewing Distance : 2.6 m (8.5 ft)
- Drive Method : PWM Constant Current

MECHANICAL SPECIFICATIONS

- Panel Dimensions : (W x H)500 x 500 mm (19.69" x 19.69")
- Panel Depth : <85 mm
- Panel Weight : 6.25 kg (13.78 lbs)
- Material : Die-Cast Magnesium Alloy
- Serviceability : Front & Rear Serviceable Magnetic Modules
- Curve Capability : Convex +6° / Concave -6°
- Max Vertical Hanging : 25 Panels
- Mounting Bolt Thread : M10 x 1.5
- Color : Matte Black

ELECTRICAL SPECIFICATIONS

- Input Voltage : 100-240V AC, 50/60Hz (Auto-Ranging)
- Power Consumption : (Max)110 W
- Power Consumption : (Avg)33 W
- Power Linking : Up to 9 units @ 120V
- Power Connectors : Seetronic PowerCON In/Out
- Data Connectors : Seetronic RJ45 / EtherCON In/Out
- Receiving Card : A8s-N
- PCB : 4-Layer Board with AOB Technology

ENVIRONMENT & STANDARDS

- Operating Temperature : -10°C to +40°C
- Humidity : 10% - 90% RH (Non-condensing)
- Storage Temperature : -20°C to +60°C
- Certification : CE, RoHS Compliant, CSA Special Publication SPE-1000-21
- IP Rating : (Front/Rear)IP30 (Indoor Use Only)

INCLUDED ACCESSORIES

- Road Case (Optional)
- Power Linking Cables (Seetronic)
- Data Linking Cables (Seetronic)
- Curving Locks (Built-in)
- Rigging Hardware (Optional)

CERTIFICATION

- CSA Special Publication SPE-1000-21

LED PERFORMANCE

- Pixel Pitch : 3.9 mm
- LED Type : High-contrast SMD, Leading Brand
- LED Configuration : 3-in-1 SMD
- Module Resolution : 96 x 96 pixels
- Panel Resolution : 128 x 256 pixels
- Brightness (Calibrated) : 4,400 NITS
- Brightness (Max) : >5,000 NITS
- Contrast Ratio : High dynamic contrast
- Refresh Rate : 3,840 Hz
- Gray Scale Processing :16-bit
- Scan Mode : 1/16 Constant Current
- Viewing Angle : (H/V)140° / 140°
- Minimum Viewing Distance : 4 m (13.12 ft)
- Drive Method : PWM Constant Current

MECHANICAL SPECIFICATIONS

- Panel Dimensions : (W x H) 500 x 1000 mm (19.69" x 39.37")
- Panel Depth : <90 mm
- Panel Weight : 11 kg (24.75 lbs)
- Material : Die-Cast Magnesium Alloy
- Serviceability : Front & Rear Serviceable Magnetic Modules
- Curve Capability : Convex +6° / Concave -6° (Optional)
- Max Vertical Hanging : 25 Panels
- Mounting Bolt Thread : M10 x 1.5
- Color : Matte Black

M-3.9 OUTDOOR



ELECTRICAL SPECIFICATIONS

- Input Voltage : 100-240V AC, 50/60Hz (Auto-Ranging)
- Power Consumption : (Max)110 W
- Power Consumption : (Avg)75 W
- Power Linking : Up to 4 units @ 120V
- Power Connectors : Seetronic PowerCON In/Out
- Data Connectors : Seetronic RJ45 / EtherCON In/Out
- Receiving Card : A5s-Plus
- PCB : 4-Layer Board with AOB Technology

ENVIRONMENT & STANDARDS

- Operating Temperature : -20°C to +50°C
- Humidity : 10% - 90% RH (Non-condensing)
- Storage Temperature : -30°C to +60°C
- Certification : CSA Approved, CE, RoHS Compliant
- IP Rating : IP65 (Weatherproof, Outdoor Use)

INCLUDED ACCESSORIES

- Road Case (Optional)
- Power Linking Cables (Seetronic)
- Data Linking Cables (Seetronic)
- Curving Locks (Built-in)
- Rigging Hardware (Optional)

CERTIFICATION

- CSA Special Publication SPE-1000-21



Scan the QR code for more product details

UPC# : 673324965210



Scan the QR code for more product details

UPC# : 673324965210

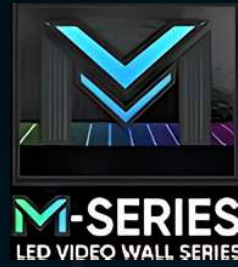

M-P 2.9 OUTDOOR

LED PERFORMANCE

- Pixel Pitch: 2.9 mm
- LED Type: SMD1515, high-performance outdoor grade
- Calibrated Illuminance: 4500 NITS
- Maximum Illuminance: >5,000 NITS
- Viewing Angle (H/V): 140° / 140°
- Minimum Viewing Distance: 7.5 ft (2.3 m)
- Display Refresh Rate: 7,680 Hz
- Drive Type: Scan Mode 1/21
- Receiver Card: A5 Plus
- Panel Resolution: 168 × 168 pixels
- IC Model: CFD455

MECHANICAL SPECIFICATIONS

- Panel Dimensions: 19.69" × 39.37" (500 × 1000 mm)
- Panel Weight: 18.2 lb (12.5 kg)
- Panel Housing Material: Die-Cast Magnesium
- Module Material: Glass-filled polycarbonate
- Exterior Color: Black
- Threaded Bolt: M10 × 1.5
- Maximum Vertical Hang: 15 panels

ELECTRICAL SPECIFICATIONS

- Input Voltage: 100–240V AC, 50/60 Hz (auto-ranging)
- Power Linking: Up to 15 units @ 120V
- Power Connectors: Standard outdoor-grade connectors
- Data Connectors: Durable RJ45 / EtherCON type
- PCB: 4-layer heavy-duty board with enhanced stability

ENVIRONMENT & STANDARDS

- Operating Temperature: Suitable for harsh outdoor conditions
- Certifications: CE, FCC, UKCA, RoHS compliant, and CSA Special Publication SPE-1000-21
- Safety Labels: Over-voltage, electrical hazard, and product safety markings included
- IP Rating: Weather-resistant design (based on outdoor module materials)

INCLUDED ACCESSORIES

- Road Case (Optional)
- Power Linking Cables (Seetronic)
- Data Linking Cables (Seetronic)
- Curving Locks (Built-in)
- Rigging Hardware (Optional)

CERTIFICATION

- CSA Special Publication SPE-1000-21



FLEXNOVA P15

ELECTRICAL SPECIFICATIONS

- Operating Voltage: 24V DC
- Maximum Power Consumption: 400W (per 10m roll)
- Control Protocol: ART-NET / DMX
- Playback Mode: ART-NET / SD Card
- Signal Cascade: Supported

PHYSICAL SPECIFICATIONS

- Standard Length: 10 meters per roll
- Product Size: 0.24m × 10m
- Weight (including controller): 2kg
- Color: Black
- Installation Type: Flexible surface mount
- IP Rating: IP40

OPTICAL SPECIFICATIONS

- Pixel Pitch: P15 (15mm)
- LED Type: 2020 RGB
- Brightness: Up to 300 cd
- Beam Angle: 120°
- Grey Scale: 256 Levels
- Pixel Matrix Count: 16 × 660
- Viewing Performance: High transparency mesh structure

ENVIRONMENTAL CONDITIONS

- Operating Temperature: -20°C to 65°C
- Storage Temperature: -20°C to 65°C

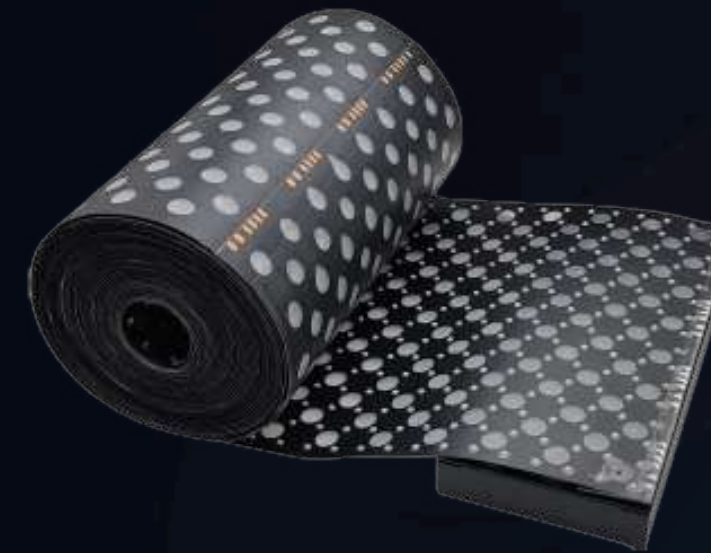

Scan the QR code for more product details



Scan the QR code for more product details

SMART FAST FOLD SCREEN

LED VIDEO WALL

SMART FAST FOLD SCREEN



- **Screen Format:** 4:3 & 16:9
- **Projection Area:** 100" – 400"
- **Frame Material:** High-strength anodized aluminum (lightweight), optional black anodized finish
- **Frame Tube Size:** 32x32 / 32x64
- **Locking Mechanism:** Tool-free snap / lever lock system with intuitive leg-to-frame connection
- **Surface Material:** RF-welded matte fabric – 8K/16K ready optical grade
- **Surface Type:** Foldable and seamless
- **Surface Finish Options:** Front or rear projection available
- **Binding Type:** RF-welded for durability and precision fit
- **Corner Fixing:** Matte snap caps for secure and clean finish
- **Feet Quantity:** 2 pcs
- **Transport Case:** Heavy-duty rolling flight case with internal padding and wheels
- **Applications:** Events, Conferences, Weddings, AV setups, Cinema, and Rental solutions
- **Certification:** CSA Special Publication SPE-1000-21

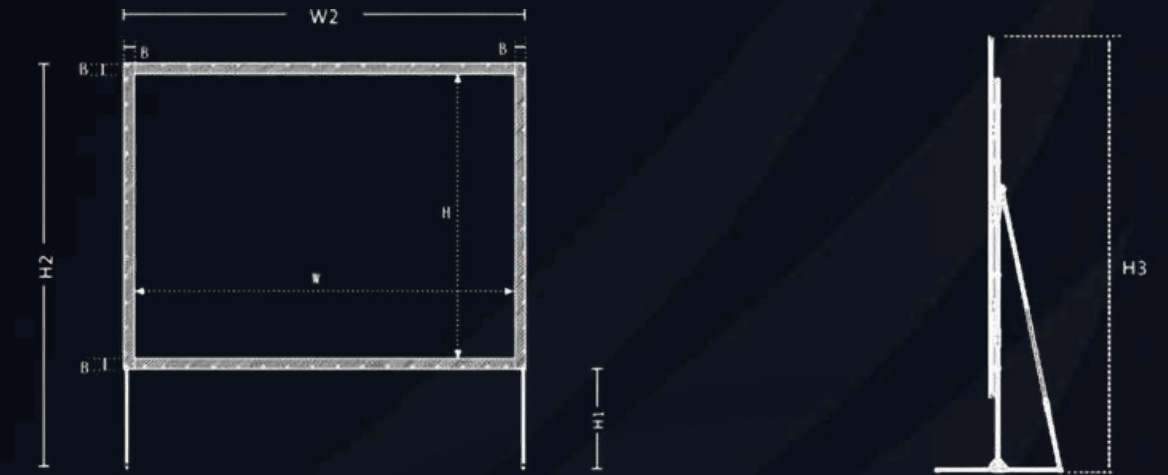

FORMAT: 4:3

Size Specifications

FORMAT: 16:9

Spec	Pipe Size	Projection Area (W×H mm)	Side Frame (mm)	Ground Clearance H1 (min-max mm)	Project Mode	Screen Width (mm)	Screen Total Height (min-max mm)	Foot Width (mm)	Foot Height (mm)	Foot Amt	Packing Box (L×W×H mm)	Flight Case (L×W×H mm)	N.W. (kg)	G.W. (kg)
100"	32x32	2033x1524	75	71-1272	Front / Rear	2183	2262-2871	1044	2262	2	1120x350x320	1095x280x300	23	26
120"	32x32	2438x1830	75	143-1044	Front / Rear	2588	2262-2949	1044	2262	2	1120x350x320	1095x280x300	26.5	29.5
150"	32x32	3053x2287	75	290-1641	Front / Rear	3203	3162-4003	1044	3162	2	1210x450x345	1185x380x325	34.5	38.5
180"	32x32	3657x2746	75	285-1336	Front / Rear	3807	3162-4157	1044	3162	2	1210x450x345	1185x380x325	38	42
200"	32x64	4065x3046	100	135-1186	Front / Rear	4215	3162-4337	1044	3162	2	1485x490x480	1460x435x455	40	45
250"	32x64	5080x3810	100	274-1028	Front / Rear	5230	4062-4938	1275	4062	2	1485x490x480	1460x440x440	54	60
300"	32x64	6096x4572	100	248-2347	Front / Rear	6296	6012-7019	1575	6012	2	1720x600x480	1685x490x445	68	75
350"	32x64	7112x5334	100	204-2716	Front	7312	7012-7938	1575	7012	2	1720x600x480	1685x490x445	95	110
400"	32x64	8128x6096	100	185-3247	Front	8328	7012-8938	1575	7012	2	1720x600x480	1685x490x445	118	130

Spec	Pipe Size	Projection Area (W×H mm)	Side Frame (mm)	Ground Clearance H1 (min-max mm)	Projection Mode	Screen Width (mm)	Screen Total Height (min-max mm)	Foot Width (mm)	Foot Height (mm)	Foot Amount	Packing Box (L×W×H mm)	Flight Case (L×W×H mm)	N.W. (kg)	G.W. (kg)
100"	32x32	2213x1246	75	210-1411	Front / Rear	2363	2262-2737	1044	2262	2	1120x350x320	1095x280x300	23	26
120"	32x32	2657x1492	75	237-1288	Front / Rear	2807	2262-2855	1044	2262	2	1120x350x320	1095x280x300	26.5	29.5
150"	32x32	3320x1866	75	350-1851	Front / Rear	3473	3162-3792	1044	3162	2	1210x450x345	1185x380x325	34.5	38.5
180"	32x32	3985x2240	75	388-1734	Front / Rear	4135	3162-4054	1044	3162	2	1210x450x345	1185x380x325	38	42
200"	32x64	4427x2490	100	189-1689	Front / Rear	4577	3162-4279	1275	3162	2	1485x490x480	1460x435x455	40	45
250"	32x64	5534x3113	100	178-1678	Front / Rear	5734	4062-4874	1275	4062	2	1485x490x480	1460x440x440	54	60
300"	32x64	6641x3735	100	144-1944	Front	6841	4512-5779	1575	4512	2	1720x600x480	1685x490x445	68	75
350"	32x64	7754x4358	100	155-1850	Front	7954	6012-6779	1575	6012	2	1720x600x480	1685x490x445	95	110
400"	32x64	8855x4981	100	150-1875	Front	9055	6012-6956	1575	6012	2	1720x600x480	1685x490x445	118	130

TRUSS & MORE



LD-12 BLK TRUSS

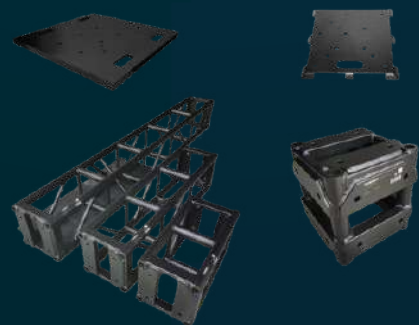

QUICK STAGE



SMART STAGE

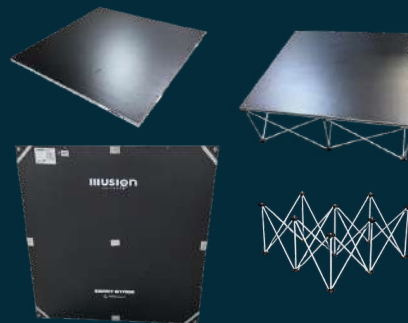

VELVET CURTAINS



TELESCOPIC CROSS-BARS



LD-12 BLK 12" Aluminum Bolt Truss

LD-12 BLK TRUSS

MODELS AVAILABLE

- IT-BT1208 BLK - 8FT PILLAR
- IT-BT1204 BLK - 4FT PILLAR
- IT-BT1202 BLK - 2 FT PILLAR
- IT-BT12-6W BLK - 6 WAY BLOCK BOLTED
- IT-BT1222 BASE - 22 INCH BY 22 INCH BASE PLATE
- IT-BT1236 BASE - 36 INCH BY 36 INCH BASE PLATE

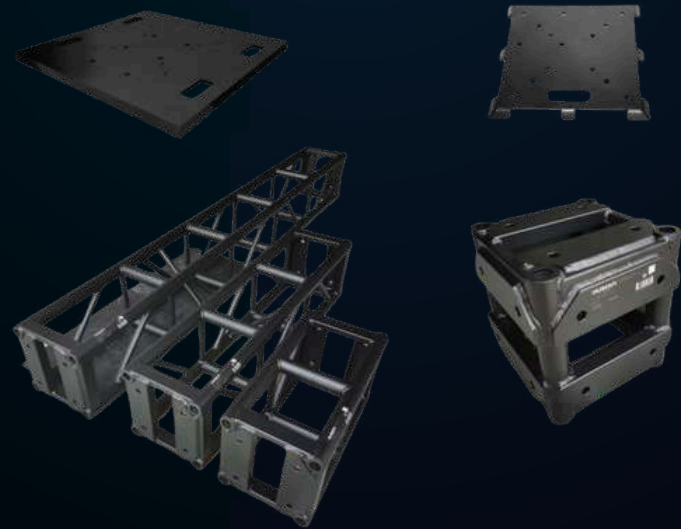

Span m	Uniformly Distributed Load Kg/m		Centre Point Load Kg		Third Point Load Kg(2x)		Quarter Point Load Kg(3x)		5th Point Load Kg(4x)	
	mm	mm	mm	mm	mm	mm	mm	mm	mm	mm
2	1705	1.6	1705	1.3	1278.7	1.6	852.5	1.5	710.4	1.6
4	420.7	6.4	841.5	5.1	631.1	6.5	420.7	6.1	350.6	6.4
6	182.9	14.4	548.8	11.6	411.6	14.7	274.4	13.7	228.6	14.5
8	99.7	25.7	398.7	20.9	299	26.2	199.4	24.5	166.1	25.8
10	61.2	40.3	305.8	33.2	229.3	41	152.9	38.5	127.4	40.5
12	40.2	58.3	241.1	48.6	181	59.3	120.7	55.8	100.6	58.7
13	33.2	68.6	215.7	57.6	161.8	69.8	107.9	65.8	89.9	69
14	27.6	79.8	193.2	67.5	144.9	81.2	96.6	76.7	80.5	80.3
15	23.1	91.9	173.3	78.3	129.9	93.4	86.6	88.5	72.2	92.5
16	19.4	104.9	155.3	90.2	116.5	106.6	77.7	101.3	64.7	105.5



Scan the QR code for more product details

QUICK STAGE



QUICK STAGE

HD DECK CLAMP

- Order code: QSI 6136
- Heavy duty aluminium deck clamp offering a more even load distribution and greater clamping force compared to standard deck clamps.
- Heavy duty clamp for clamping adjacent decks together
- A minimum of one clamp is to be used per running metre of joint
- Aluminium pressure pads

TWO LEG CLAMPS

- Heavy duty clamp for clamping two square 60mm or round 48mm legs together
- Version: 60mm, 48mm

DECK LEVELLER

- Order code: QSI 6011
- A handy insert designed to be fixed in the side groove on TFR Stage Decks to assist when levelling stage platforms
- A minimum of one leveller is to be used per running metre of joint

FOUR LEG CLAMPS

- Heavy duty clamp for clamping two square 60mm or round 48mm legs together
- Version: 60mm, 48mm

DECK CLAMP

- Order code: QSI 6010
- For clamping adjacent decks together
- A minimum of one clamp is to be used per running metre of joint



UPC# : 673324965111



Scan the QR code for more product details

SMART STAGE



SMART STAGE

TECHNICAL SPECIFICATIONS

- Platform Size : 4' x 4' (1.22m x 1.22m)
- Platform Material : High-density birch plywood with anti-slip finish
- Frame Material : Heavy-duty aluminum alloy
- Load Capacity : 750 kg per square meter (1530 lbs per square foot)
- Height Options : 8", 16", 24", 32" (20cm, 40cm, 60cm, 80cm)
- Connection System : Secure locking system with quick-release mechanism
- Surface Finish : Black textured anti-slip surface
- Weight (Per Panel) : 55 lbs (25 kg) approx. for 4' x 4' platform
- Accessories : Guardrails, steps, ramps, skirting, storage carts
- Weatherproofing Water-resistant coating for outdoor use



UPC# : 673324965128



Scan the QR code for more product details

STAGE VELVET CURTAINS



FABRIC & MATERIAL

- Material: Premium Polyester Velour Velvet
- Weight Options: 15 oz / sq. yd & 22 oz / sq. yd
- Finish: Dense, light-absorbing pile surface for superior blackout performance
- Texture: Soft-touch velvet with deep matte finish, minimizing stage reflections
- Color: Jet Black (custom colors available on request)
- Opacity: 98-100% blackout (depending on lighting conditions)

AVAILABLE CURTAIN SIZES

- 20 ft (H) x 15 ft (W) – 4-inch pocket top + bottom eyelets
- 16 ft (H) x 15 ft (W) – 4-inch pocket top
- 12 ft (H) x 15 ft (W) – 4-inch pocket top
- 8 ft (H) x 15 ft (W) – 4-inch pocket top

CERTIFICATION & STANDARDS

- NFPA 701-2023 – Flame Retardant Certified (SGS Lab Tested)
- CA117 – California Fire Code Certified
- CSA & North American Standards Compliant
- Lab-tested to meet professional stage and venue fire safety code

CONSTRUCTION & FINISHING

- Top Hem: 4-inch sewn pocket (standard)
- Bottom Hem: Reinforced with grommets / eyelets for secure hanging (on select models)
- Edges: Double-stitched for durability and fray resistance
- Stage Skirts: Available with heavy-duty Velcro backing for fast setup and teardown

STAGE SKIRTS (VELOUR, 22 OZ)

- 1 m (3.3 ft) H x 8 ft W – Velcro mount
- 16 in (1.3 ft) H x 8 ft W – Velcro mount



Scan the QR code for more product details

UPC# : 602835339708

TELESCOPIC POSTS (UPRIGHT)

Fixed Height Uprights

- ILD-UFH1.2 → Fix Height 1.2m Upright
- ILD-UFH1.5 → Fix Height 1.5m Upright
- ILD-UFH2.5 → Fix Height 2.5m Upright

Two-Piece Adjustable Uprights

- ILD-2AU35 → 3'-5' Adjustable Upright, Two-Piece Pipe (0.9-1.5m)
- ILD-2AU47 → 4'-7' Adjustable Upright, Two-Piece Pipe (1.2-2.1m)
- ILD-2AU58 → 5'-8' Adjustable Upright, Two-Piece Pipe (1.5-2.4m)
- ILD-2AU610 → 6'-10' Adjustable Upright, Two-Piece Pipe (1.8-3m)
- ILD-2AU712 → 7'-12' Adjustable Upright, Two-Piece Pipe (2.1-3.6m)
- ILD-2AU814 → 8'-14' Adjustable Upright, Two-Piece Pipe (2.4-4.2m)
- ILD-2AU916 → 9'-16' Adjustable Upright, Two-Piece Pipe (2.7-4.8m)
- ILD-2AU1018 → 10'-18' Adjustable Upright, Two-Piece Pipe (3-5.4m)
- ILD-2AU1120 → 11'-20' Adjustable Upright, Two-Piece Pipe (3.3-6m)
- ILD-2AU1426 → 11'-26' Adjustable Upright, Two-Piece Pipe (3.6-7.9m)

Three-Piece Adjustable Uprights

- ILD-3AU614 → 6'-14' Adjustable Upright, Three-Piece Pipe (1.8-4.2m)
- ILD-3AU717 → 7'-17' Adjustable Upright, Three-Piece Pipe (2.1-5.1m)
- ILD-3AU820 → 8'-20' Adjustable Upright, Three-Piece Pipe (2.4-6m)
- ILD-3AU1026 → 10'-26' Adjustable Upright, Three-Piece Pipe (3-7.9m)



Scan the QR code for more product details

UPC# : 673324964961

TRUSS & MORE



GROUNDLIFT MAX

TECHNICAL SPECIFICATIONS

PRODUCT TYPE

- LED Ground Support & Lifting System

SUPPORTED SCREEN TYPE

- Curved & Straight LED Panels

LIFTING MECHANISM

- Manual / Mechanical Lifting Pipe System

MAXIMUM LIFT HEIGHT

- Up to 1.5 meters

MATERIAL

- Aluminium Alloy 6061-T6 / 6082-T6

STRUCTURAL DESIGN

- Rear-support ground stack system

INSTALLATION METHOD

- Ground-based assembly

APPLICATION

- Indoor & Outdoor Events

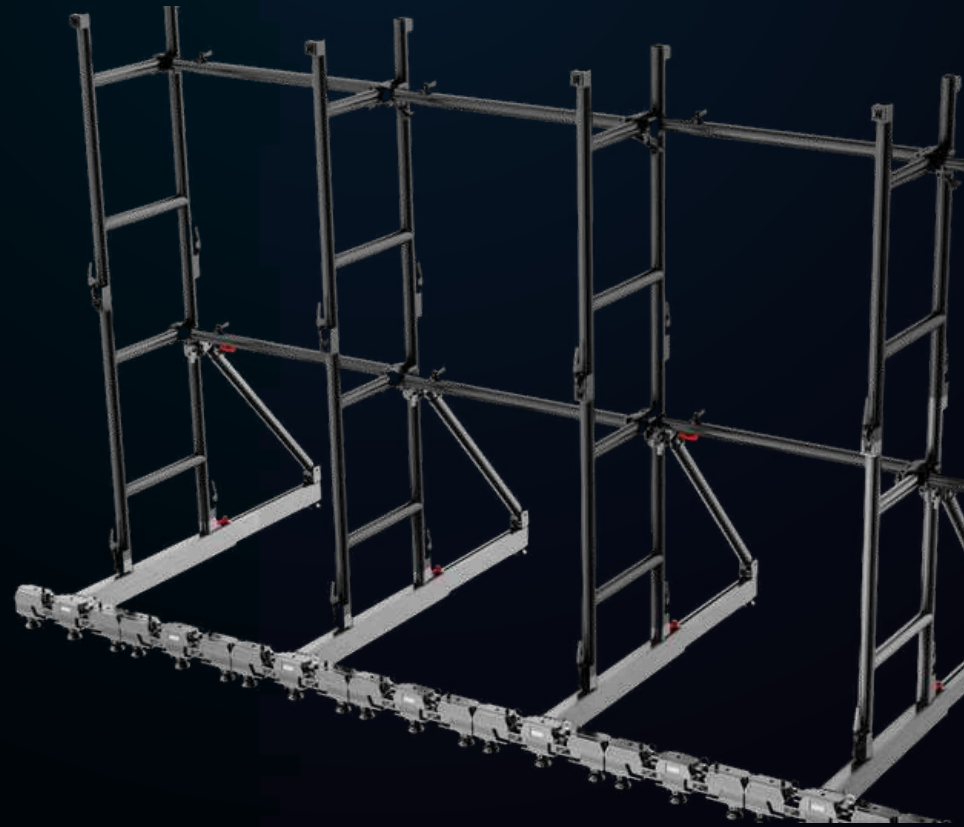

Scan the QR code for more product details



GROUNDLIFT PRO

TECHNICAL SPECIFICATIONS

MATERIAL

- Aluminum Alloy 6061-T6

COLOR

- Black

BUILDING SHAPE

- On-ground Straight Screen
- Off-ground Straight Screen

LIFTING PIPE HEIGHT

- Adjustable Height: 0.7-1.5 m
- Fixed Height: 0.5-1.5 m



Scan the QR code for more product details

PRIME

EFFECTS LIGHT



**PRIME 10000
RGB**



**PRIME MH 12W
RGB LASER**



**PRIME
LASER X6**



**PRIME
40000 RGB**



PRIME
10000 RGB

PRIME 10000 RGB

LIGHT SOURCE

- Diodes: Japan Nichia
- Red Laser: 3000mW @ 638nm
- Green Laser: 3000mW @ 525nm
- Blue Laser: 4000mW @ 450nm

BUILD & COOLING

- Optical Path Sealing: Unique double-layer structure, fully sealed
- Cooling System: Air cooling
- IP Rating: IP54

CERTIFICATION

- CSA Special Publication SPE-1000-21

TECHNICAL DETAILS

- Voltage: 110-240V, 50/60Hz
- Modulation: 100K Analog / TTL
- Scanning Angle: Maximum 60°
- Scanner Speed: 25K

DIMENSIONS & WEIGHT

- Product Dimensions: 32.5 x 24.5 x 19 cm
- Net Weight: 5.5 KG
- Package Dimensions: 36 x 36 x 27 cm
- Gross Weight: 6.45 KG



Scan the QR code for more product details

UPC# : 673324964961

PRIME
MH 12W RGB

PRIME MH 12W RGB LASER

POWER & OPERATION

- Voltage: AC100-230V, 50/60Hz
- Power Consumption: 250W max

SCAN SYSTEM

- Speed: 40kpps
- Maximum Scan Angle: ±30°
- Horizontal Scan Range: 540° (16-bit precision)
- Vertical Scan Range: 270° (16-bit precision)
- Reset Function: Automatic error correction

LASER MODULATION & BEAM SPECS

- Modulation Type: Analog
- Laser Beam Diameters:
 - 12W/10W: 6 x 6.5mm
 - 6W: 3 x 6.5mm
- Beam Divergence: < 1.2mrad

CONTROL MODES

- DMX512 Channels: 6/40
- Other Modes: Auto, Sound-Activated, Master-Slave, ILDA, SD Card

CONTROL INTERFACES

- DMX Connector: 3-pin DMX512
- ILDA Connector: 25-pin DB
- Expansion: SD Card Slot



Scan the QR code for more product details

UPC# : 6733249649189

PRIME
LASER X6

PRIME LASER X6

SPECIFICATIONS

- Model : PRIME LASER X6
- Laser Power : (Red)150mW
- Laser Power : (Green)100mW
- Laser Power : (Blue)500mW
- Beam Aperture : Φ18mm
- Laser Classification : Class 3B (IEC 60825-1)
- Dimensions : 1000 x 22.5 x 201.2 mm

- Net Weight : 10 Kg
- Power Input : 100-240V AC, 50/60Hz
- Power Consumption : 108W
- DMX Channels : 7/9/12/36/48/54/66CH
- Operating Modes : Auto Show, Sound Show
- Series Step Motor Series / Fat Beam Series

CERTIFICATION

- CSA Special Publication SPE-1000-21



Scan the QR code for more product details

UPC# : 673324964961

PRIME 40000 RGB



LIGHT SOURCE

- Product Name: Prime 4000 RGB
- Laser Power: 4W RGB Full Color
- Light Source
- Red: 10000mW @ 638nm*1
- Green: 14000mW @ 525nm*1
- Blue: 16000mW @ 450nm*1
- Scanner: 50K
- Max Scan Angle: 60°
- Voltage: 110-240V | 50/60Hz
- Cooling: Air Cooling
- Modulation: 100K Analog / TTL
- Control Modes
- ILDA / DMX512 / Auto / Music / Master-Slave
- DMX Mode: 3-Pin DMX512
- ILDA: International Standard 25 pins
- Divergence: < 1.0 mrad
- Light Source Lifespan: ≥ 20,000 hrs
- Working Temperature: -20°C to 45°C
- Protection System: Auto beam shut-off when focused statically
- IP Rate: IP65
- Optical Design: Double-Layer structure sealed path
- Product Size: 54 × 60.5 × 44.5 cm
- Net Weight: 36 kg
- Flight Case Size: 70 × 76 × 54 cm
- Gross Weight: 52 kg
- Certification: CSA Special Publication SPE-1000-21

BOOTH SERIES



BOOTH SMART DJ

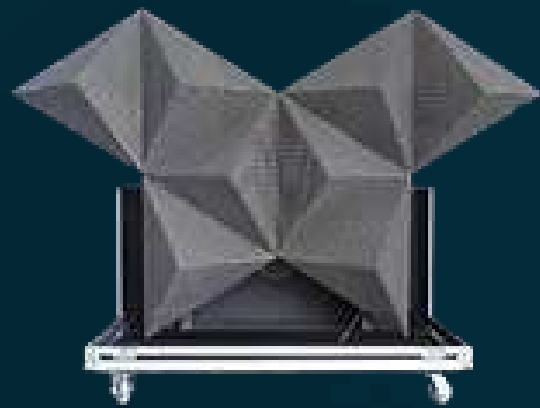

BOOTH PRO DJ

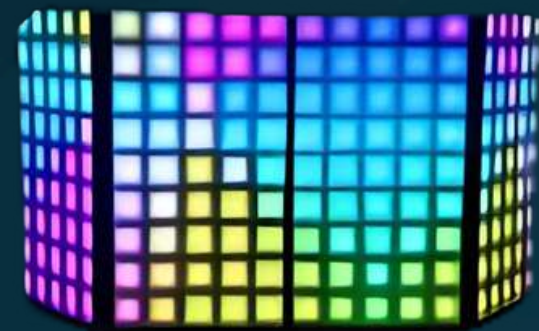

BOOTH SMART DJ

SPECIFICATIONS

- Product Name: SMART DJ BOOTH
- Overall Dimension: 2400 × 1521 × 740 mm
- Voltage: AC110-220V, 60Hz / 50Hz
- Max Power: 1400 W
- Control: Mobile, iPad & Computer Simply Plug & Play
- Pixel Pitch & LED Standard: 6.15 mm & SMD3528
- Scan Mode & Pixel Density: 1/13 & 26,449 dot/m²
- P.W.: 170 Kg
- Refresh Rate & Brightness: 960 Hz & 1200 CD/m²
- Life Span: ≥ 30,000 Hours
- Certification: CE, RoHS, UL, CSA Special Publication SPE-1000-21

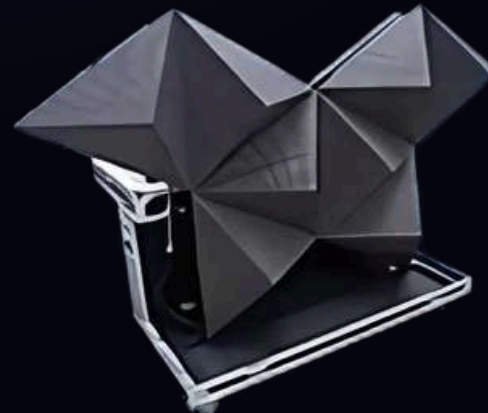
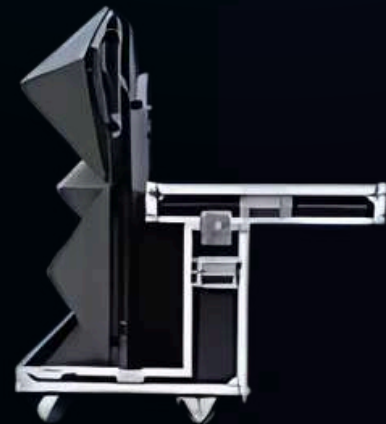
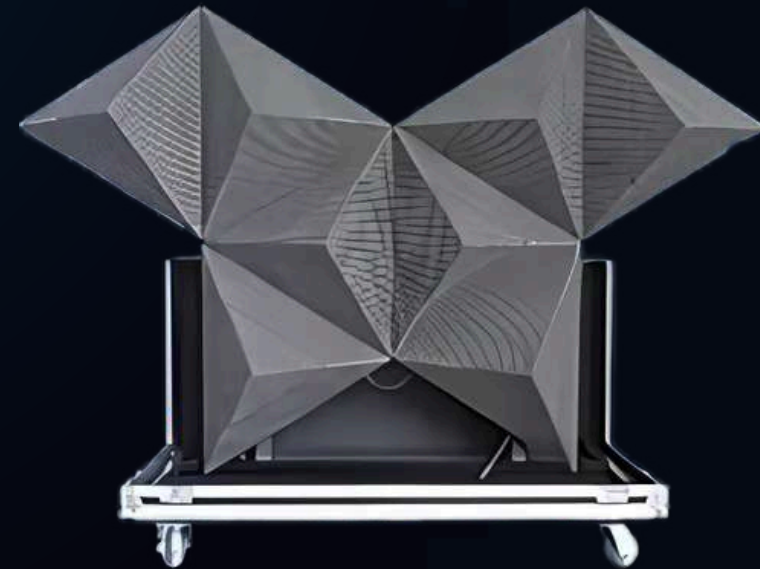

Scan the QR code for more product details

BOOTH PRO DJ

SPECIFICATIONS

- Product Name: PRO DJ BOOTH
- Overall Dimension: Spread Size 2330 × 1980 × 1190 mm
- Fold Size 2510 × 1180 mm
- Voltage: AC110-220V, 60Hz / 50Hz
- Max Power: 1.4 W
- Control: DMX 512, Software, Sound
- DMX: 6 CH, 31 CH
- LED Quantity: RGB LED 1620 Pieces
- P.W.: 230 Kg
- Main Material: Aluminium
- Life Span: ≥ 50,000 Hours
- CSA Special Publication SPE-1000-21

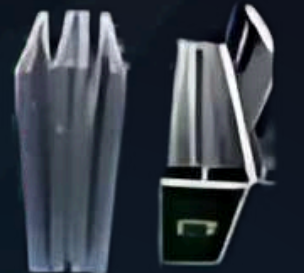
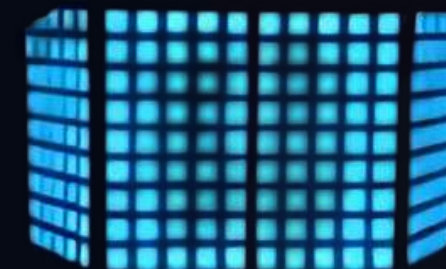

Scan the QR code for more product details

DMX CABLES

Pro-Grade Cables

CABLES & ACCESSORIES



3-PIN DMX CABLES

- 10FT
- 25FT
- 50FT
- 100FT



5-PIN DMX CABLES

- 5FT
- 10FT
- 25FT
- 50FT
- 100FT
- 3-PIN FEMALE DMX ADAPTER
- 5-PIN FEMALE DMX ADAPTER



STAGE BOXES & SNAKES

- CAT6 Box to 3-Pin DMX
- CAT6 Box to 3-Pin DMX
- 4-Way Reel Snake Cable 80M
- 1-Way Reel Snake Cable 50M
- 24-Channel Audio Snake Cable (30M)



MULTI-CHANNEL SNAKES

- 8-Way Audio Snake Cable 100FT
- 8-Way DMX Snake Cable (100FT)
- 6-Way Audio Snake Cable (50FT)
- 16-Way DMX Snake Cable (50FT)



POWERCON COMPATIBLE

- Main Power Cable with Plug 10FT / 14AWG
- Interconnect Power Cable 10FT / 14AWG
- Interconnect Power Cable 25FT / 14AWG



TRUE1 COMPATIBLE

- Main Power Cable 10FT / 14AWG
- Interconnect Power Cable 10FT / 14AWG
- Main Power Cable 25FT / 14AWG

DMX CABLES

Pro-Grade Cables

CABLES & ACCESSORIE

3-PIN DMX CABLES



05FT

SPECIFICATIONS

- Model: DMX01BL-05FT
- Type: 3-Pin XLR (Male to Female) DMX Cable
- Length: 05FT (1.5m)
- Conductor: $(20 \times 0.12)^2 \times 64 \times 0.12$
- Outer Diameter (OD): 6.0mm
- Connector Type: 3-pin XLR (M-F)
- Color: Black with nickel-plated connectors for durability
- Compatibility: DMX512 digital protocol and XLR-based lighting systems
- Volume: 0.043 m³



Scan the QR code for more product details

10FT

SPECIFICATIONS

- Brand: Illusion Universe
- Type: 3-Pin XLR (M-F) DMX Cable
- Length: 10FT (3 meters approx.)
- Conductor Size: $(0.20 \times 7) \times 2 + 64 \times 0.12$
- Outer Diameter (OD): 6.0 mm
- Connectors: 3-Pin XLR Male to Female
- Compatibility: DMX 512 protocol and XLR-based lighting systems
- Application: Stage shows, DJs, Theater Productions, Concerts, Corporate Events, Touring, and Broadcast setups



Scan the QR code for more product details

25FT

SPECIFICATIONS

- Model: DMX001B-BL-25FT
- Type: 3-Pin XLR (Male to Female) DMX Cable
- Length: 25FT (7.6m)
- Construction: $(0.20 \times 7)^2 + 640.12$
- Outer Diameter (OD): 6.0 mm
- Connector Type: 3-pin XLR (M-F)
- Color: Black cable with blue-coded connectors for easy identification
- Packaging: 100 pcs/CTN
- Carton Size: 47 x 35 x 27.5 cm
- Volume: 0.15 m³



Scan the QR code for more product details

50FT

SPECIFICATIONS

- Model: DMX001B-BL-50FT
- Type: 3-Pin DMX Cable (Male-Female)
- Conductor: $(0.2037) + (264 \times 0.12)$
- Outer Diameter: 6.0mm
- Length: 50FT
- Connectors: XLR 3-Pin (Male/Female)
- Carton Size (LxWxH): 47 x 35 x 27.5 cm
- Volume: 0.15 m³
- Quantity per Carton: 100 pcs



Scan the QR code for more product details

100FT

SPECIFICATIONS

- Model: DMX001B-BL-100FT
- Type: 3-Pin DMX Cable (Male-Female)
- Conductor: $(0.2037) + (264 \times 0.12)$
- Outer Diameter: 6.0mm
- Length: 100FT
- Connectors: XLR 3-Pin (M/F)
- Carton Size (LxWxH): 43 x 32 x 23 cm
- Volume: 0.20 m³
- Qty per Carton: 50 pcs



Scan the QR code for more product details

DMX CABLES

Pro-Grade Cables

CABLES & ACCESSORIE

5-PIN DMX CABLES



05FT

SPECIFICATIONS

- Model: DMX001B-BL-5PIN-5FT
- Type: 5-Pin DMX Cable (Male-Female)
- Length: 5FT
- Connectors: XLR 5-Pin (Male to Female)
- Carton Size (LxWxH): 47 × 35 × 27.5 cm
- Volume: 0.06 m³
- Quantity per Carton: 100 pcs



Scan the QR code for more product details

10FT

SPECIFICATIONS

- Model: DMX01B-BL-5PIN-10FT
- Type: 5-Pin DMX Cable
- Connector: 5-pin female to 5-pin male
- Length: 10 Feet (3 meters approx.)
- Quantity per Carton: 50 pcs
- Carton Size: 47 × 35 × 27.5 cm
- Volume per Carton: 0.09 m³
- Unit Price: \$3.00
- Box Price (100 pcs): \$300.00



Scan the QR code for more product details

25FT

SPECIFICATIONS

- Model: DMX01B-BL-5PIN-25FT
- Type: 5-Pin DMX Cable
- Connector: 5-pin female to 5-pin male
- Length: 25 Feet (approx. 7.5 meters)
- Quantity per Carton: 30 pcs
- Carton Size: 47 × 35 × 27.5 cm
- Volume per Carton: 0.15 m³
- Unit Price: \$4.40
- Box Price (100 pcs): \$440.00



Scan the QR code for more product details

50FT

SPECIFICATIONS

- Model: DMX01B-BL-5PIN-50FT
- Type: 5-Pin DMX Cable
- Connector: 5-pin female to 5-pin male
- Length: 50 Feet (approx. 15 meters)
- Quantity per Carton: 50 pcs
- Carton Size: 43 × 32 × 23 cm
- Volume per Carton: 0.20 m³
- Unit Price: \$8.00
- Box Price (50 pcs): \$400.00



Scan the QR code for more product details

DMX CABLES

Pro-Grade Cables

100FT

SPECIFICATIONS

- Brand: Illusion Universe
- Model: DMX001B-BL-5PIN-100FT
- Type: 100FT DMX Cable
- Connector Type: 5-Pin Female to 5-Pin Male
- Length: 100 Feet (30.48 Meters)
- Material: Shielded cable with protective rugged outer jacket
- Carton Size (per CTN): 43 x 32 x 23 cm
- Carton Volume: 0.20 m³
- Quantity per Carton: 8 pcs
- Unit Price: \$12.95 USD



Scan the QR code for more product details

CABLES & ACCESSORIE

5-PIN DMX CABLES



5-PIN MALE TO 3-PIN FEMALE DMX ADAPTER

SPECIFICATIONS

- Brand: Illusion Universe
- Model: DMX001B-BL-3PIN-MALE-TURN-10INCH
- Type: DMX Adapter Cable
- Connector Type: 3-Pin Male to 5-Pin Female
- Length: 10 Inch (25 cm approx.)
- Carton Size (per CTN): 45 x 32 x 23 cm
- Carton Volume: 0.02 m³
- Quantity per Carton: 180 pcs
- Unit Price: \$2.90 USD



Scan the QR code for more product details

3-PIN MALE TO 5-PIN FEMALE DMX ADAPTER

SPECIFICATIONS

- Brand: Illusion Universe
- Model: DMX001B-BL-3PIN-MALE-TURN-10INCH
- Type: DMX Adapter Cable
- Connector Type: 3-Pin Male to 5-Pin Female
- Length: 10 Inch (25 cm approx.)
- Carton Size (per CTN): 45 x 32 x 23 cm
- Carton Volume: 0.02 m³
- Quantity per Carton: 180 pcs
- Unit Price: \$2.90 USD



Scan the QR code for more product details

DMX CABLES

Pro-Grade Cables

CABLES & ACCESSORIE STAGE BOXES & SNAKES



CAT6 BOX TO 3-PIN DMX

SPECIFICATIONS

- Brand: Illusion Universe
- Model Number: BS20-4F
- Product Type: RJ45 Adapter – CAT6 Female to 4 × XLR Female
- Input Connector: RJ45 CAT6 Female
- Output Connectors: 4 × XLR Female
- Carton Quantity: 40 pcs / carton
- Carton Size: 50 cm (L) × 40 cm (W) × 22 cm (H)
- Carton Volume: 0.01 m³
- Unit Price: USD \$11.50
- Total (40 pcs): USD \$920.00



Scan the QR code for more product details

CAT6 BOX TO 3-PIN DMX

SPECIFICATIONS

- Brand: Illusion Universe
- Model Number: BS20-4M
- Product Type: RJ45 Adapter – CAT6 Female to 4 × XLR Male
- Input Connector: RJ45 CAT6 Female
- Output Connectors: 4 × XLR Male
- Carton Quantity: 40 pcs / carton
- Carton Size: 50 cm (L) × 40 cm (W) × 22 cm (H)
- Carton Volume: 0.01 m³
- Unit Price: USD \$11.50
- Amount (for 8 pcs): USD \$92.00



Scan the QR code for more product details

4-WAY REEL SNAKE CABLE 80M

SPECIFICATIONS

- Brand: Illusion Universe
- Model: RS11-4X-80M
- Cable Type: 4-way CAT6 Network Cable
- Outer Diameter (OD): 22.0mm
- Length: 80 Meters
- Quantity per Carton (CTN): 1 unit
- Carton Size (L x W x H): 59 x 44 x 50 cm
- Volume (CBM): 0.52
- Net Weight / Unit: (Based on packaging, approx. -specs can be added if you want exact weight)
- Applications: Live concerts, stage productions, studio setups, AV installations, rental companies



Scan the QR code for more product details

1-WAY REEL SNAKE CABLE 50M

SPECIFICATIONS

- Brand: Illusion Universe
- Model: RS12A-50M
- Type: 1-Way Reel Snake Cable
- Cable Category: Network Cable CAT6
- Length: 50M (164FT)
- Design: Mounted on heavy-duty reel
- Quantity per Carton: 1 pc/CTN
- Carton Size: 57 x 42 x 49 cm
- Volume: 0.94 m³
- Color: Black



Scan the QR code for more product details

24-CHANNEL AUDIO SNAKE CABLE (30M)

SPECIFICATIONS

- Brand: Illusion Universe
- Model: BS01RB-2004X-30M
- Type: 24-Channel Audio Snake Cable (20 sends + 4 returns)
- Length: 30M (98FT)
- Quantity per Carton: 1 pc/CTN
- Carton Size: 49 x 45.5 x 24 cm
- Volume: 0.11 m³
- Color: Black with multi-channel connectors
- Applications: Stage, studio, broadcasting, touring

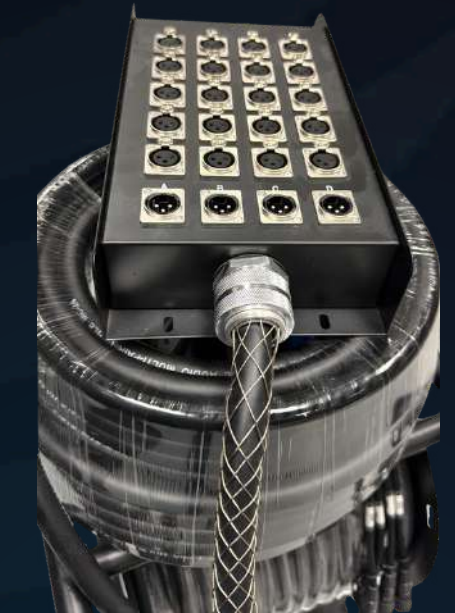

Scan the QR code for more product details

DMX CABLES

Pro-Grade Cables

CABLES & ACCESSORIE MULTI-CHANNEL SNAKES



8-WAY AUDIO SNAKE CABLE 100FT

SPECIFICATIONS

- Brand: Illusion Universe
- Model: 8CH-100FT
- Type: 8-Way Audio Snake Cable
- Connectors: 8 x XLR Male to 8 x XLR Female
- Length: 100FT (30M)
- Quantity per Carton: 4 pcs/CTN
- Carton Size: 49 x 45.5 x 24 cm
- Volume: 0.05 m³
- Color: Black

8-WAY DMX SNAKE CABLE (100FT)

SPECIFICATIONS

- Brand: Illusion Universe
- Product Type: 8-Channel Audio Snake Cable
- Connectors: 8 XLR Male (SPIN) to 8 XLR Female (SPIN)
- Length: 100FT (30.5 meters)
- Outer Diameter (OD): 13mm
- Cable Structure: 20/0.10BC+PE(LI)*2C+DW/0.15TC + AL Foil + PVC3.0
- Shielding: AL Foil + PVC for superior noise reduction
- Durability: Heavy-duty PVC coating for long-term reliability
- Application Style: Multi-core design for professional stage and studio use



Scan the QR code for more product details

16-WAY AUDIO SNAKE CABLE (50FT)

SPECIFICATIONS

- Brand: Illusion Universe
- Product Type: 16-Channel Audio Snake Cable
- Connectors: 16 XLR Male to 16 XLR Female
- Length: 50FT (15.2 meters)
- Outer Diameter (OD): 13mm
- Cable Structure: 20/0.10BC+PE(LI)*2C+DW/0.15TC + AL Foil + PVC3.0
- Shielding: AL Foil + PVC for signal protection
- Durability: Rugged PVC coating for stage and studio use
- Packaging: 4 pieces per carton | Carton size: 49 x 45.5 x 24 cm



Scan the QR code for more product details

16-WAY DMX SNAKE CABLE (50FT)

SPECIFICATIONS

- Brand: Illusion Universe
- Product Type: 16-Way DMX Snake Cable
- Connector Type: XLR (5-pin) Male to XLR (5-pin) Female
- Cable Length: 50FT (15.2 meters)
- Outer Diameter (OD): 13mm
- Construction: 20/0.10BC + PE(LI) * 2C + DW/0.15TC + AL Foil + PVC3.0
- Shielding: AL Foil + PVC – reduces signal loss, hum, and interference
- Durability: Rugged PVC jacket suitable for professional use and road setups
- Packaging: 4 pieces per carton | Carton size: 49 x 45.5 x 24 cm
- Volume: 0.05 m³



Scan the QR code for more product details



Scan the QR code for more product details

DMX CABLES

Pro-Grade Cables

CABLES & ACCESSORIE POWERCON COMPATIBLE



MAIN POWER CABLE WITH PLUG 10FT / 14AWG

SPECIFICATIONS

- Cable Type: PowerCon / TRUE1 Compatible Main Power Cable
- Cable Length: 10 Feet (3 Meters)
- Conductor Gauge: 14 AWG
- Conductor Material: 100% Pure Copper (UL Certified)
- Connector Type A: Seetronic PowerCon / TRUE1 Compatible Connector (Blue)
- Connector Type B: Standard 3-Pin Power Plug (Male)
- Voltage Rating: 250V AC
- Current Rating: 15A
- Jacket Material: Flexible and Durable PVC
- Certifications: UL Certified
- Compatibility: Compatible with PowerCon and TRUE1 systems
- Application Use: Stage Lighting, Audio Equipment, Touring Rigs, Event Power Distribution
- Color: Black
- Warranty: Lifetime Warranty



Scan the QR code for more product details

INTERCONNECT POWER CABLE 10FT / 14AWG

SPECIFICATIONS

- Cable Type: PowerCon Compatible Interconnect Power Cable
- Cable Length: 10 Feet (3 Meters)
- Conductor Gauge: 14 AWG
- Conductor Material: 100% Pure Copper (UL Certified)
- Connector Type A: Seetronic PowerCon Male (Blue)
- Connector Type B: Seetronic PowerCon Female (Grey)
- Voltage Rating: 250V AC
- Current Rating: 15A
- Jacket Material: Flexible and Durable PVC
- Certifications: UL Certified
- Compatibility: PowerCon-compatible devices and fixtures
- Application Use: Lighting Interconnect, Stage Power Linking, Audio Equipment
- Color: Black
- Warranty: Lifetime Warranty



Scan the QR code for more product details

INTERCONNECT POWER CABLE 25FT / 14AWG

SPECIFICATIONS

- Cable Type: PowerCon / True1 Compatible Interconnect Power Cable
- Length: 25FT (7.6 Meters)
- Conductor Size: 14AWG (2.08mm²) Oxygen-Free Copper
- Connector Type: Seetronic Locking PowerCon-Compatible (Blue/Gray) or True1
- Certifications: UL Certified
- Voltage Rating: 250V AC
- Current Rating: Up to 15 Amps
- Outer Jacket Material: Flexible PVC (Black)
- Temperature Rating: -20°C to +70°C
- Wire Construction: 3-Conductor, Heavy-Duty Copper Wire
- Strain Relief: Integrated for extended cable life
- Cable Diameter: Approx. 10mm
- Warranty: Lifetime Replacement Warranty



Scan the QR code for more product details

DMX CABLES

Pro-Grade Cables

CABLES & ACCESSORIE TRUE1 COMPATIBLE



MAIN POWER CABLE 10FT / 14AWG

SPECIFICATIONS

- Brand: Illusion Universe
- Model: PowerCon / True1 Compatible Power Cable
- Cable Type: Power Cable (True1 / PowerCon Compatible)
- Connectors: Seetronic True1-Compatible Locking Power Plug
- Cable Length: 10 Feet (3 Meters)
- Wire Gauge: 14 AWG (Heavy Duty)
- Certification: UL Certified Components
- Jacket Material: Flexible PVC, Durable Outer Layer
- Color: Black
- Usage: Stage Lighting, Audio Systems, Live Events, Touring, Studio, and Permanent Installations
- Rated Voltage: 125V AC
- Rated Current: 15A
- Temperature Rating: -20°C to +70°C
- Construction: Rugged strain relief, high-flex copper conductors
- Warranty: Limited Manufacturer Warranty



Scan the QR code for more product details

INTERCONNECT POWER CABLE 10FT / 14AWG

SPECIFICATIONS

- Brand: Illusion Universe
- Product Type: True1 Compatible Interconnect Power Cable
- Length: 10 Feet (Approx. 3 Meters)
- Cable Gauge: 14 AWG
- Certification: UL Certified, RoHS Compliant
- Connector Type: Seetronic True1 Compatible PowerCON Connectors (Locking)
- Rated Voltage: 250V AC
- Rated Current: 15 Amps Max
- Jacket Material: Heavy-Duty Flexible PVC
- Color: Black
- Operating Temperature: -20°C to +70°C
- Usage: Professional Lighting, Audio, Stage & Studio Equipment
- Durability: Heavy-Duty Touring Grade
- Country of Design: Designed for Canada



Scan the QR code for more product details

MAIN POWER CABLE 25FT / 14AWG

SPECIFICATIONS

- Brand: Illusion Universe
- Product Type: True1 Compatible Main Power Cable
- Length: 25 Feet (Approx. 7.6 Meters)
- Cable Gauge: 14 AWG
- Certification: UL Certified, RoHS Compliant
- Connector Type: Seetronic True1 Compatible PowerCON Connectors (Locking Type)
- Rated Voltage: 250V AC
- Rated Current: 15 Amps Max
- Cable Material: Pure Copper Conductors with Heavy-Duty Flexible PVC Jacket
- Color: Black
- Operating Temperature: -20°C to +70°C
- Usage: Professional Lighting, Audio, Stage & Studio Applications
- Durability: Touring-Grade / Long-Life Reliability
- Country of Design: Designed for Canada



Scan the QR code for more product details



CABLES & ACCESSORIE

GAFF-X PRO GAFFER TAPE



GAFF-X PRO GAFFER TAPE

SPECIFICATIONS

- Product Name: GAFF-X PRO
- Size: 3 Inch x 60 Yards (75mm x 55m)
- Material: Pure Cotton Cloth
- Finish: Matte (Non-Reflective)
- Adhesive Type: High Strength, Residue-Free
- Color: Black (expandable to other colors)
- Application: Indoor / Professional Use



Scan the QR code for more product details

CONTROLLERS & NETWORKING



DMX EXTENDER &
ARTNET NODE

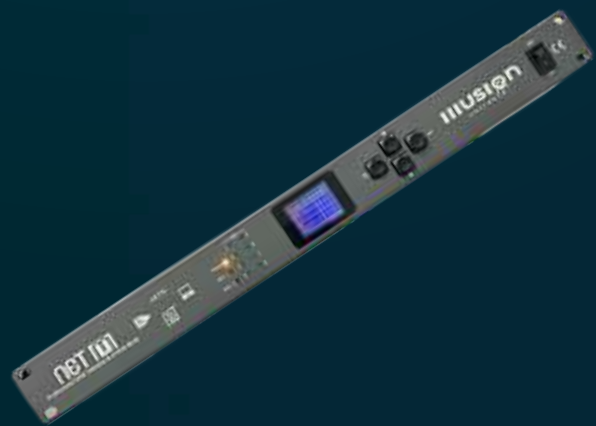

DATA STREAM M
PRO



DMX SPLITTER



DATA STREAM M
TRUSS



CONTROLLERS & NETWORKING

NET M

DMX EXTENDER & ARTNET NODE

SPECIFICATIONS

- Model Name : NET M
- Product Type : Professional DMX Extender & ArtNet Node
- Series : NET M
- Supported Protocols : Art-Net, sACN, DMX512, RDM
- DMX Ports : 8 configurable ports (Input/Output), 3-pin XLR / optional 5-pin XLR
- Art-Net Universes : 8 universes (4096 channels), expandable to 32,768 universes (16,777,216 channels)
- DMX Modes : SINGLE / HTP / LTP
- Frame Rate : Adjustable up to 40Hz/sec
- Signal Handling : HOLD / ZERO / OFF
- Configuration Interface : Web Browser Interface
- Isolation : 100% electrical isolation between all ports
- Ethernet Connectivity : High-speed Ethernet I/O with zero linking delay
- LED Indicators : Per-port Signal & Activity indicators, Power indicator
- Input Voltage : AC88-256V, 50/60Hz
- Rackmount Size : 19" 1U
- Dimensions : 482mm x 168mm x 44mm
- Weight : 1.7 Kg (3.74 lbs)
- Designed By : Illusion Universe Co. Ltd., Canada
- Manufactured In : P.R.C.
- Certifications : CE, FCC, UKCA, RoHS Compliant



Scan the QR code for more product details

Data STREAM M

DATA STREAM M PRO

SPECIFICATIONS

- Brand: Illusion Universe
- Product Type: True1 Compatible Interconnect Power Cable
- Length: 10 Feet (Approx. 3 Meters)
- Cable Gauge: 14 AWG
- Certification: UL Certified, RoHS Compliant
- Connector Type: Seetronic True1 Compatible PowerCON Connectors (Locking)
- Rated Voltage: 250V AC
- Rated Current: 15 Amps Max
- Jacket Material: Heavy-Duty Flexible PVC
- Color: Black
- Operating Temperature: -20°C to +70°C
- Usage: Professional Lighting, Audio, Stage & Studio Equipment
- Durability: Heavy-Duty Touring Grade
- Country of Design: Designed for Canada



Scan the QR code for more product details

Data STREAM M

DATA STREAM M TRUSS

SPECIFICATIONS

- Power Input : AC 88-256V, 50/60Hz
- Internal Fuse : T2A
- DMX Channels Supported : 512 channels (DMX-512 protocol)
- Maximum Fixtures : 31 before distributor, 32 per output
- Output Drivers : Independent driver for each DMX output
- Isolation : 100% electrical isolation between all I/O
- Data Transmission : RS-485 protocol
- Connector Type : 3-pin XLR (standard DMX connectors)
- Termination Support : 120-ohm resistor (Pin 2 & Pin 3)
- Weight : 0.8 kg
- Operating Temperature : -10°C to +45°C
- Housing Material : Aluminum alloy
- Dimensions : 15 x 11.5 cm





DMX EXTENDER & ARTNET NODE

SPECIFICATIONS

- Power Input : AC 88-256V, 50/60Hz
- Internal Fuse : T2A
- DMX Input: 1
- DMX Pass-Thru : 1
- DMX Outputs : 4 independent outputs
- Output Driver Independent driver at each output
- Electrical Isolation : Yes
- Power Indicator : Yes
- Dimension : 400 × 54 × 53 mm
- Weight : 0,5 kg
- Housing : Durable metal construction



Scan the QR code for more product details

DECO LIGHTS



VIDEO BAR 1000



VIDEO BAR SMART
CONTROLLER

- CL-404R CONTROLLER
- CL-804PS CONTROLLER
- CL-104PS CONTROLLER
- CL-C200F RAINPROOF



VIDEO BAR 360



FLEXIBLE NEON
TUBE



RGB NEON
STRIP LIGHT

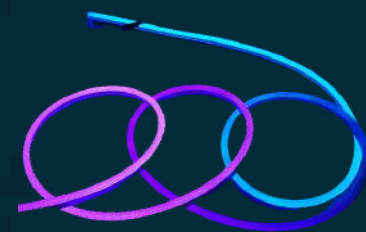

VIDEO PIXEL
RINGS





DECO LIGHTS

VIDEO BAR 1000

TECHNICAL SPECIFICATIONS

- Voltage: DC 24V
- Power Consumption: 13W per meter (Max)
- LED Type: 5050 RGB
- LED Quantity: 64 LEDs per meter
- Pixel Count: 64 Pixels
- Beam Angle: 120° / 270° / 330°
- Grey Scale: 256 Levels
- Control Channel: GRB
- Length: 1 Meter
- IP Rating: IP65 (Weather Resistant)
- PC Cover Options: Round Diffuser / Square Diffuser / Flat Black Diffuser
- Weight: 0.56 kg



TECHNICAL SPECIFICATIONS

- Model: CL-T100W
- Working Voltage: DC24V
- Max Power: 24W – 25W
- LED Type: 5050 RGB
- LED Quantity: 144 LEDs
- Pixels: 24 Pixels
- Channel: RGB
- Grey Scale: 256
- Beam Angle: 360°
- Diameter: 40 mm
- Length: 1 m (Multiple sizes available)
- Waterproof Rating: IP65
- Weight: 0.53 kg
- Size:
L=520/600/680/760/840/920/1000/1080/1160/1240
/1320/1400/1480/1560/1640/1720/1800/1880/1960/2
040
- Pixel
=12/14/16/18/20/22/24/26/28/30/32/34/36/38/40/
42/44/46/48/50

VIDEO BAR 360



Scan the QR code for
more product details



Scan the QR code for
more product details

DECO LIGHTS

VIDEO BAR SMART CONTROLLER



CL-404R CONTROLLER

SPECIFICATIONS

- Working Voltage: AC100-240V
- Output Voltage: DC24V
- Power: 1000W
- Output Ports: 4 Ports
- Control Mode: ART-NET / DMX / sACN
- Working Mode: ARTNET / SD Card / Ring
- Port Loading Capacity: 4 × 680 Pixels
- Supported Cascaded Units: Up to 254 Controllers
- Product Dimensions: 245 × 225 × 125 mm
- Gross Weight: 3.5 kg



Scan the QR code for more product details

CL-804PS ART-NET CONTROLLER

SPECIFICATIONS

- Input Voltage: AC110V – AC220V
- Output Voltage: DC5V – DC24V
- Working Voltage: 24V
- Maximum Output Power: 1400W
- Output Ports: 8 Ports
- Pixels Supported: 8 × 680 Pixels
- Control Protocols: Art-Net / DMX / sACN / RDM
- Working Modes: Art-Net Mode / SD Card Mode
- Supported IC Types: WS2811 / SK6812 / UCS1903 / UCS8903 / UCS9812 / DMX512
- Cascaded Units: Up to 254 Controllers
- Product Size: 340 × 310 × 120 mm
- Product Weight: 6 kg



Scan the QR code for more product details

CL-104PS ART-NET CONTROLLER

SPECIFICATIONS

- Working Voltage: AC110-220V
- Output Voltage: DC5-24V
- Output Power: 200W
- Output Port: 1 Port
- Control Protocol: Art-Net / DMX / sACN
- Working Mode: Art-Net / SD Card
- Pixel Capacity: 4 × 680 Pixels
- Supported IC: CL05, CL16, WS2811, SK6812, DMX, UCS8903, UCS1903
- Effect Recording: 32 Built-in Effects
- Cascading: Up to 254 Units
- Software Support: MAD_SHOW, MADMAPPER, MADRIX, RESOLUME, MA2
- RDM Function: Supported
- Product Size: 320 × 62 × 50 mm
- Product Weight: 1.2 kg



Scan the QR code for more product details

CL-C200F RAINPROOF

SPECIFICATIONS

- Input Voltage: AC110-220V
- Output Voltage: DC24V
- Power: 200W
- Control Modes: ART-NET / sACN / SD Card
- Working Modes: ARTNET / SD Card
- Output Ports: 1 Port
- Maximum Pixel Control: 680 Pixels
- Cascaded Units: Up to 254 Controllers
- Effect Storage: 31 Built-in Effects
- Product Dimensions: 170 × 90 × 50 mm
- Gross Weight: 0.8 kg
- Protection Rating: IP65 (Dust & Water Resistant)

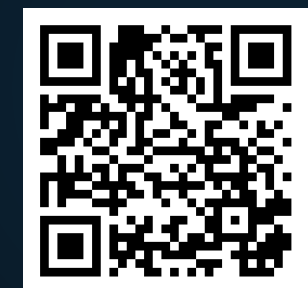

Scan the QR code for more product details

FLEXIBLE NEON TUBE

SPECIFICATIONS

- Product Name: Flexible Neon Tube
 - Tube Diameter: 40mm (D40mm)
 - Operating Voltage: DC 24V
 - Power Consumption: 20W per meter
 - LED Quantity: 120 LEDs per meter
 - Pixel Quantity: 20 pixels per meter
 - Lighting Type: 360° Flexible Milky Neon Tube
 - Control Type: Pixel-controlled (programmable)
- Material: High-quality flexible silicone/PVC housing



Scan the QR code for more product details

RGB NEON STRIP LIGHT

SPECIFICATIONS

- Product Name: RGB Neon Strip Light
- Working Voltage: DC 24V
- Maximum Power Consumption: 14.4W
- LED Type: 5050 RGB
- Grey Scale: 256 Levels
- LED Quantity: 60 LEDs
- Pixel Quantity: 10 Pixels
- Waterproof Rating: IP65
- Lighting Type: Flexible Pixel LED Neon Strip



Scan the QR code for more product details

VIDEO PIXEL RINGS

SPECIFICATIONS

- Working Voltage: DC24V
- Power Consumption: 23W
- Diameter: 10 inch
- LED Type: 3535 RGB
- LED Quantity: 240 LEDs
- Pixel Count: 60 pixels
- Control Protocol: DMX512 / ART-NET
- Channel Mode: RGB
- Grayscale: 65536 levels
- Product Weight: 0.45 kg
- Product Size: 10 inch
- IC Type: DMX512
- Connection: T-cable series connection
- Installation: Steel wire suspension / Screw fixing
- Mask Options: Transparent / Milky



Scan the QR code for more product details

AUDIO



SONICFORCE
150



ILLUSION
UNIVERSE

SONICFORCE 150

SPECIFICATIONS

- System Type: Long Range Acoustic Hailing System
- Power Output: 150W
- Max SPL: 137 ±2dB
- Frequency Response: 400Hz – 6KHz
- Coverage Angle: 30° (H) × 30° (V)
- Communication Distance: ≥ 1000m
- Effective Range: 250m – 600m
- Sensitivity: 116 ±2dB
- Speech Clarity (STIPA): 0.85
- Dimensions: 365 × 215 × 235 mm
- Weight: 6.5kg / 8.5kg



Scan the QR code for more product details

Specification	ILAS1515	ILAS1515A
RMS Power	150W / 8Ω	150W / 4Ω
Sensitivity	116 ± 2dB	116 ± 2dB
Max SPL	137 ± 2dB	137 ± 2dB
Frequency Response	400Hz – 6KHz	400Hz – 6KHz
Cover Angle	Horizontal 30° × Vertical 30°	Horizontal 30° × Vertical 30°
STIPA	0.85	0.85
Communication Distance	≥ 1000m	≥ 1000m
Dispersal Distance	250m	250m
Dimensions	365 × 215 × 235 mm	365 × 215 × 235 mm
Net Weight	6.5 kg	8.5 kg



ILLUSION UNIVERSE CO. LTD.

ADD: 10 FALCONER DR UNIT-11,
MISSISSAUGA, ON L5N 3L8, CANADA
TEL: 647 212 2609
EMAIL: SALES@ILLUSIONUNIVERSE.CA
WEB: WWW.ILLUSIONUNIVERSE.CA



WWW.FACEBOOK.COM/ILLUSIONCAD



WWW.INSTAGRAM.COM/ILLUSIONCAD/



WWW.YOUTUBE.COM/@ILLUSIONUNIVERSE