

# HYDREX

APEX 1000



## HYDREX APEX 1000

    /illusioncad

DESIGNED FOR CANADA 

**ILLUSION**  
UNIVERSE

 [www.illusionuniverse.ca](http://www.illusionuniverse.ca)

SUMMARY

Introduction .....3

Technical parameter .....7

Dimension .....9

Photometric .....10

Display .....11

DMX 512 connection .....19

Error messages .....25

Cleaning and maintenance .....27

## INTRODUCTION

Thank you for selecting the 850W LED BSWF

### **WARNING !**

This product is not suitable for household use.

You now own a professional lighting unit that offers endless possibilities. Before installing, make sure that no damage was done to your luminaire during transport.

For your own safety and that of others, please read this instruction manual carefully before installing the unit.

Anyone involved in installing, operating or servicing the 850W LED BSWF must:

- Be a qualified, authorized professional
- Strictly follow the instructions in this user manual.

Please take the time to read this manual carefully and thoroughly before installing and operating the 850W LED BSWF . You should have a good knowledge of its operating conditions and all pertinent product information.

After you have become familiar with this manual, we recommend that you keep a copy for future use. All the information found in this manual is subject to change without notice.

## SAFETY INSTRUCTIONS

Please read the safety instructions and warnings in this manual carefully before installing and operating the 850W LED BSWF.

### **WARNING!**

Risk of electric shock.

Use caution when handling. This fixture requires high voltage, which can result in electric shock.

The fixture left our factory in perfect working condition. However, if you notice a defect, immediately contact your authorized 850W LED BSWF dealer before use. The manufacturer cannot be held responsible for damages caused by a failure to follow the safety, installation or assembly instructions contained herein, or by any modification made to the 850W LED BSWF.

Failure to observe the safety, installation or assembly instructions contained herein, or any modification made to the 850W LED BSWF will render the warranty null and void.

Check that the supply voltage does not exceed the maximum authorized limit. Check that your electrical installation complies with current standards.

In all cases, make sure that the power cables attached to your fixture have not been damaged due to cuts and splices or crushed in any way.

Handle these cables with extreme caution while they are connected to a power source.

Your 850W LED BSWF conforms to Class 1 safety standards. The unit must be grounded electrically. Make sure that the power source connected to your fixture is switched off before attempting any work on it.

Installation and connection to an electrical source must be performed by an authorized installer. Our factory declines all responsibility should this fixture be installed by an unqualified person.

Never disconnect your fixture by pulling on the power cable! First unlock the connector lock ring on the power cable until it is fully disengaged, and then gently pull on the connector to disconnect the cable.

Do not connect or disconnect the power cable of your fixture with wet hands.

At first use, your fixture may give off an odor. This is a normal occurrence that should dissipate after a few minutes of operation.

### **WARNING!**

Do not connect or disconnect the power cable at your fixture if the cable is energized! This could cause arcing and damage your fixture, requiring repair.

Be careful to power off your fixture by removing the power plug from the source, before connecting or disconnecting the fixture.

Never look directly into the lamps if lit or stand directly in line with the fixture if close by.

Installation, removal or replacement of the unit must be performed with power off to prevent any risk of glare and eye injury.

### **WARNING!**

The fixture quickly becomes very hot during operation.

To avoid risk of burn, never handle or adjust the fixture while it is energized and after it has been lit for more than 10 consecutive minutes. Some parts of the fixture can reach a high temperature, particularly the body/radiator. Turn off the fixture and wait for it to cool before handling.

### **CONDITIONS OF USE**

Your 850W LED BSWF is a moving-head luminaire equipped with LED source intended for professional use (e.g., architectural, stage, television, theater, or museum lighting).

The 850W LED BSWF has an IP65 protection rating.

Condensation may form on your 850W LED BSWF in the following cases:

- Immediately after turning on the heating
- In places with fog or a high level of humidity
- When the luminaire is suddenly moved from a cold to a warm environment, or vice versa.

In such cases, you must wait until the luminaire readjusts to the ambient temperature of the room where it will be installed for operation.

Do not shake the 850W LED BSWF while installing or handling.

Do not pull the fixture by one of its cables to move it. Lift the fixture by its handles.

Choosing the appropriate place to install the fixture is essential. The following points should be observed:

- Do not expose it to a heat source.
- Do not install it near flammable materials.
- Be sure that dust or miscellaneous debris cannot clump around the body of the luminaire as this may interfere with its optimal cooling and proper operation.
- The 850W LED BSWF must be installed out of reach of the public and all persons not authorized to operate the luminaire.

We recommend a minimum distance of 5 m between the outside surface of the light and the illuminated object.

Due to the nature of its cooling principle, you should never prevent air from circulating around the body of the fixture. You must provide a minimum clearance around your fixture to allow for cooling.

The fixture can be installed in a ground pit or any other confined enclosure only under certain conditions. With this kind of installation, a system of forced ventilation should be used up to allow air to circulate freely around the fixture. The air must be constantly renewed because the luminaire cannot be operated in closed system. Failure to comply with these requirements may destroy or prematurely wear the fixture, and manufacturer cannot be held responsible. Please consult your 850W LED BSWF dealer for more information on this type of installation.

No load should be placed on the 850W LED BSWF. The fixture must not be installed in such a way as to allow a person, vehicle or any object to run over or park on it.

Never lay or drop any hard, heavy, or blunt, objects on the fixture. This includes items made of glass or porcelain (e.g., bottles, dishware, or glass beads). The fixture is made of materials such as plastic and extruded aluminum, making it resistant but not unbreakable. Objects made of hard materials such as steel or glass that fall on the unit may cause breakage of the plastic parts or the body. Our factory cannot be held responsible for the fixture's broken plastic parts or body, which are not covered under warranty.

The temperature of the room where the fixture is installed must never exceed 45°C ( $T_a = 45^\circ\text{C}$ ).

The fixture requires a 110-240 VAC supply voltage. Check that your fixtures have been installed for an application that is compatible with this information.

Check that the brackets on which you hang or attach your fixture can sustain the weight of the fixture (27kg), taking into consideration all necessary safety factors.

Do not use your fixture before being familiar with these recommendations and do not allow unqualified personnel to handle the product.

To transport your 850W LED BSWF, we strongly recommend that you use the complete original packaging, including the dense protective foam inserts.

If your 850W LED BSWF is not being used for a long period, you should disconnect the fixture from the power source.

Never dispose of the in a rubbish bin. Ensure that it is recycled.  
Please consult the current legislation in your country on recycling electronic equipment.

## **PRESENTATION AND FEATURES**

850W LED BSWF is a waterproof moving head light (IP65 protection rating) using the latest generation of high-performance of LED-type lamps.

This 850W LED BSWF can be controlled remotely by an external DMX512 signal.

The 850W LED BSWF incorporates high power white LED source.

The 850W LED BSWF requires from 34 to 56 DMX channels to be controlled via an external command system that sends a DMX512 signal (see below for details).

To adjust the settings on the fixture (i.e., DMX address, DMX operating mode and other options), a Remote Device Management (RDM)-type DMX controller may be required. The DMX RDM protocol is a universal, widely used standard.

There are a multitude of RDM DMX controllers on the market from different manufacturers . It is worth noting that an RDM DMX controller is not required to change the settings on the fixture . A light console or any standard DMX-type controller is sufficient.

The 850W LED BSWF consists of a metal frame and plastic covers. The power connectors and DMX512 signal connectors are on the back of the fixture' s base.

# TECHNICAL PARAMETER

## POWER

- Voltage: AC100~240v, 50/60Hz
- Source: 850W white LED
- Power consumption: 780W
- CT: 7200K
- Life: > 20,000H

## MOVEMENT

- Pan movement: 540° (16 bit)
- Tilt movement: 270° (16 bit)
- Advanced motion system: auto repositioning, fast, quiet and smooth

## COLORS

- **1 color wheels with 7 colors + white**
- Interchangeable, indexable, bidirectional rainbow effect
- CMY Colour Mixing
- Linear CTO (2700K-7200K)

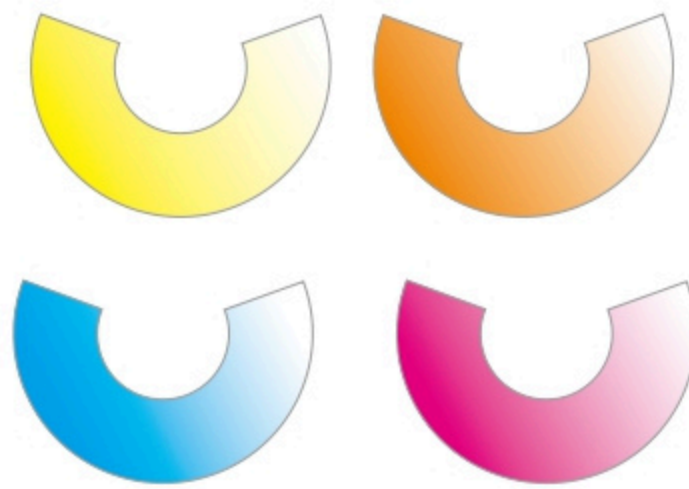
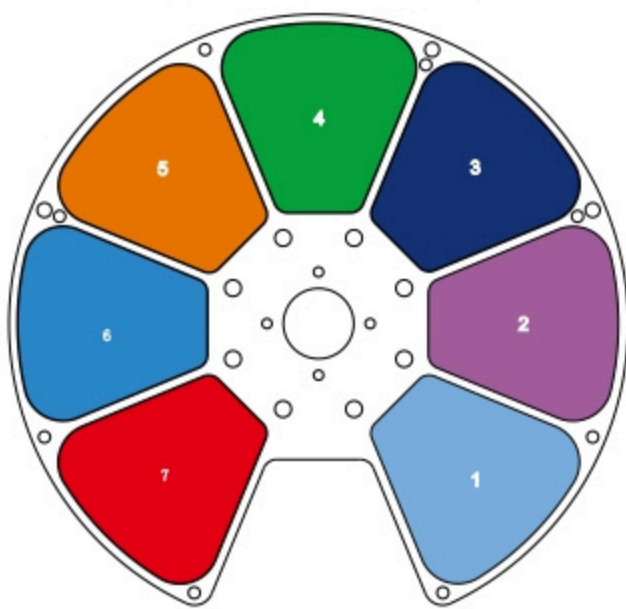

## GOBOS

- **1 Rotating gobo wheels:**  
7 interchangeable gobo + open, indexable and gobo shaking effect
- **Animation Wheel:** special dynamic flame effect

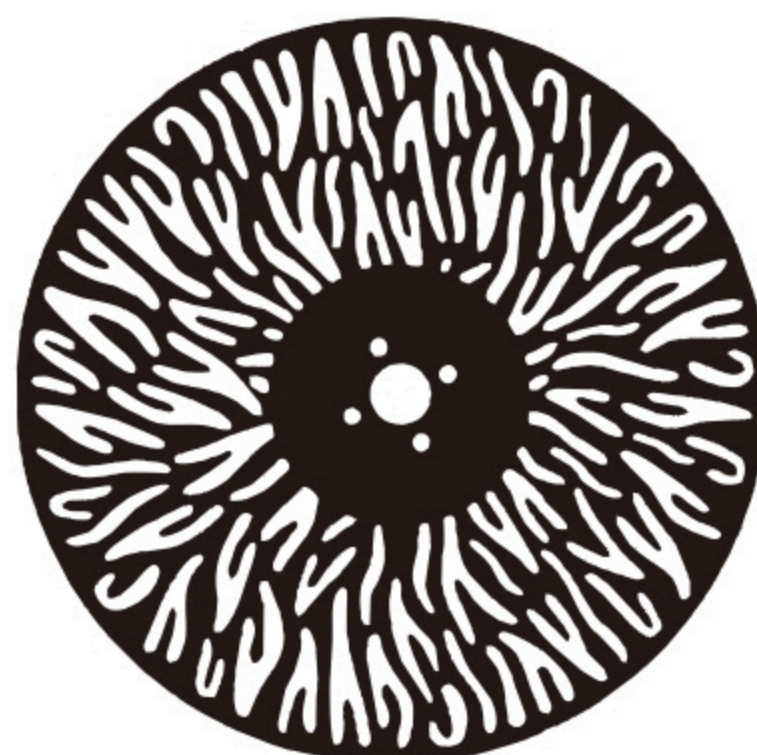
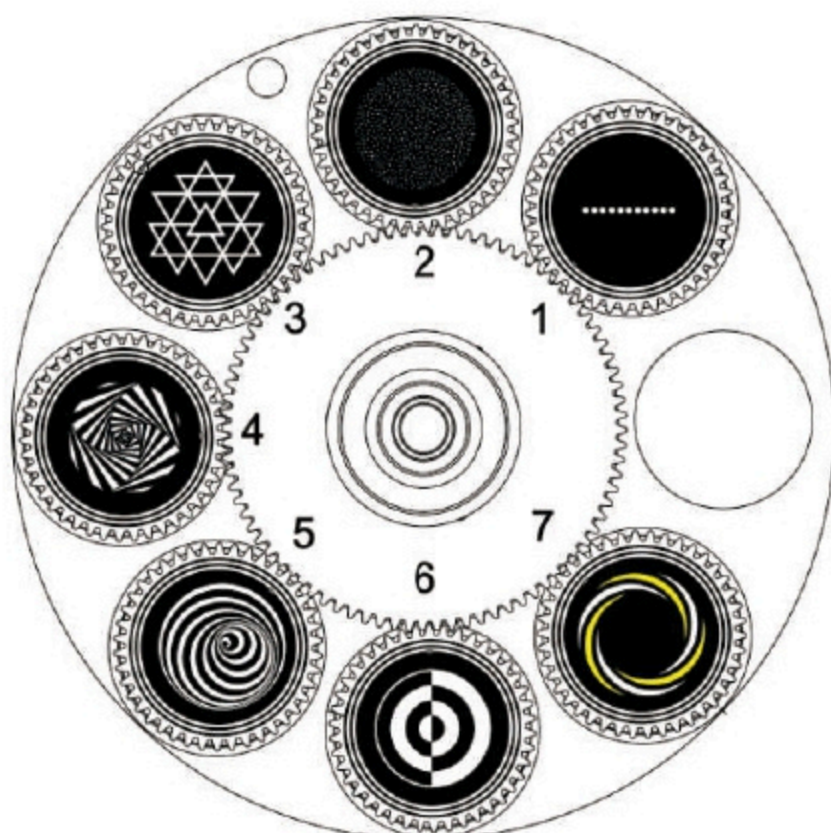

## FEATURES

- DMX channels: 36/34/56CH
- Prism: 5 facet circular prism
- Can rotate in both direction at variable speeds
- Motorized Focus
- Zoom: 3.8°- 50° linear zoom
- various strobe
- Heavy Frost
- Dimming: 0-100% linear dimming
- 5%-100% electronic Iris

## FRAMING SYSTEM

- 4 fast and smooth framing shutters,
- Each shutter blade position and angle can be controlled individually
- Movement is fast & smooth, with adjustable speed
- Framing shutters can be precise motion with smooth movement
- Each shutter blade can block out light completely
- The framing module can be rotated at +/- 60°

## DISPLAY

- 2.8 inch LCD display with English/Chinese menu
- Auto lock and display flip
- Pan/ Tilt reverse

## SOFTWARE

- Remote reset DMX address, fixture reset
- Sound control by DMX

## OTHER SPEC

- Input signal isolation
- Optional ArtNET control
- RDM compatible
- Self-adjusting variable speed fans
- Excess-temperature protection

## DIMENSIONS AND WEIGHT

- Dimension:418x300x655mmmm
- Packing Dimension : 67X58X52.5cm
- Net Weight: 27 KG
- Gross Weight: 31KG

# Dimension

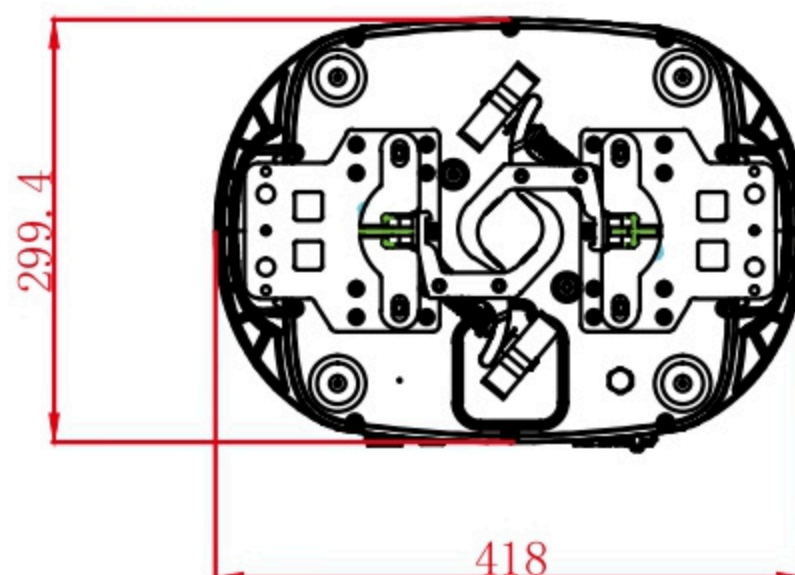
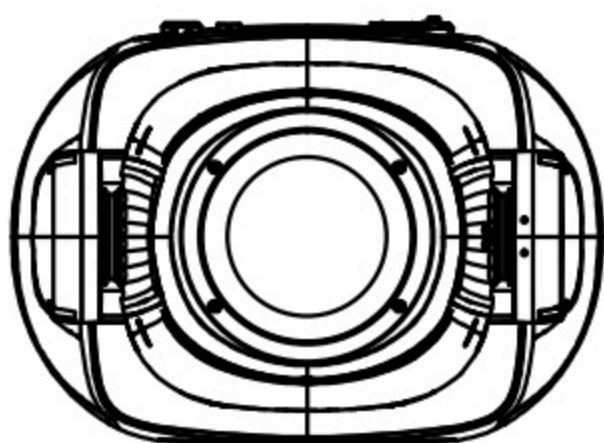
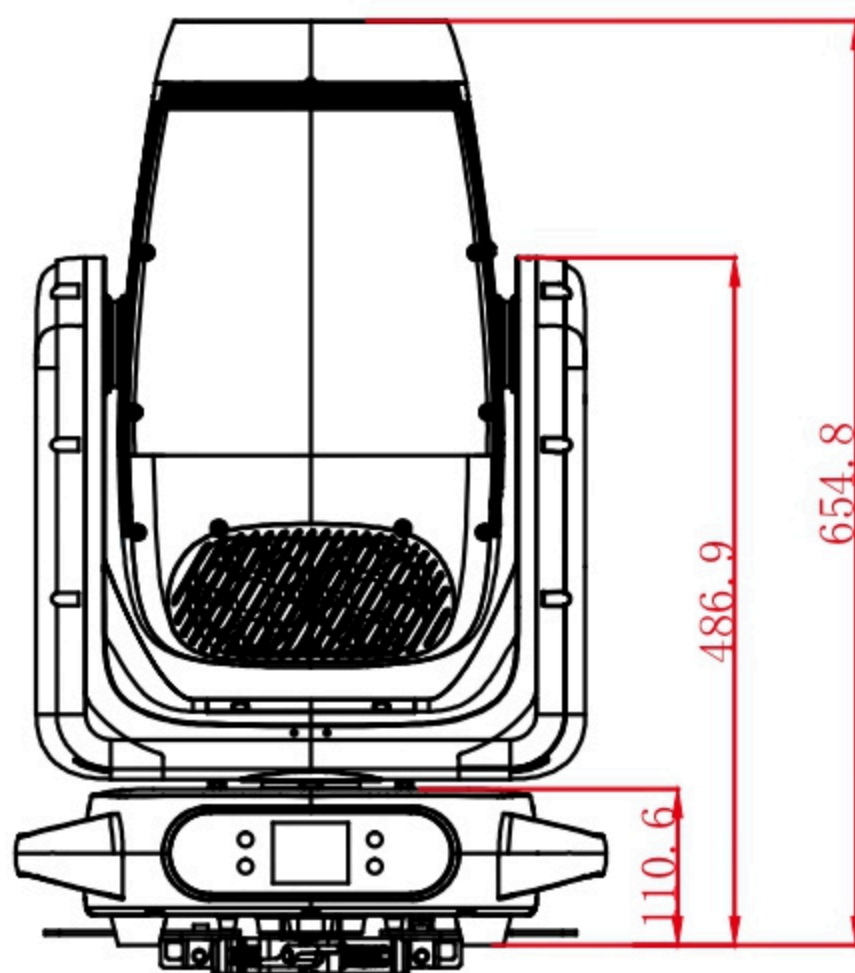
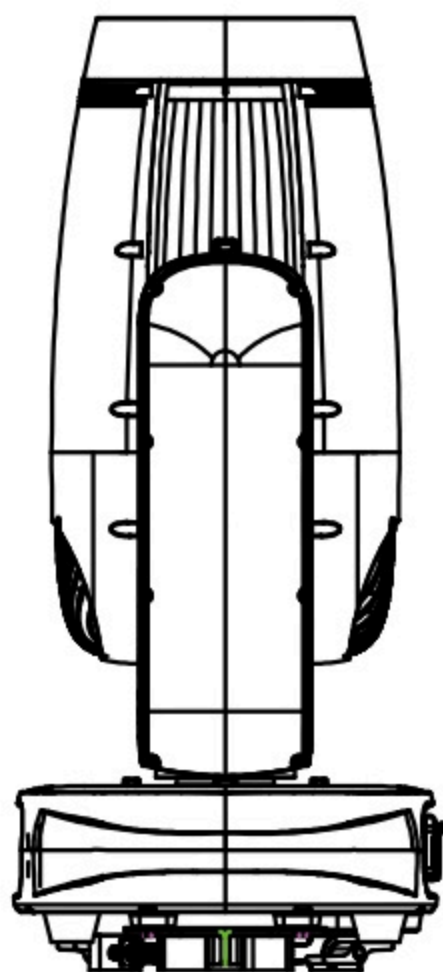
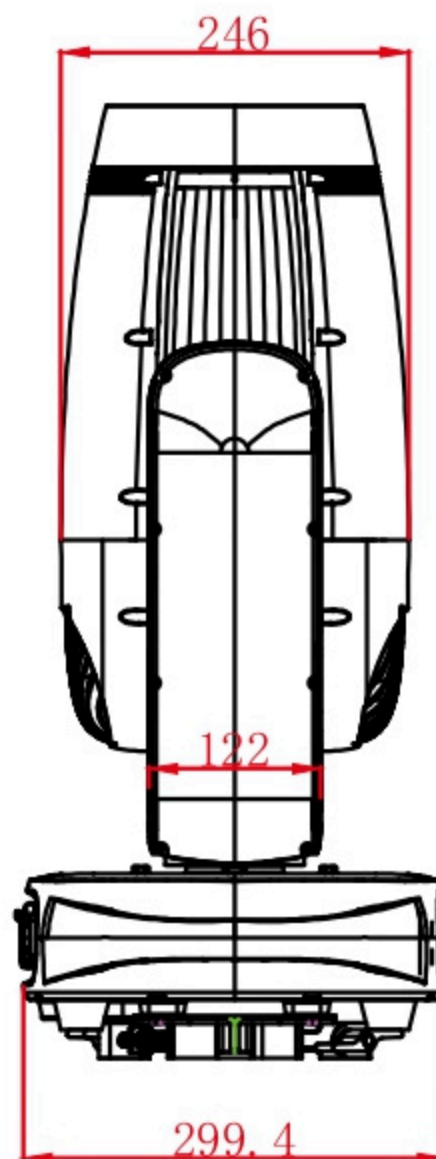
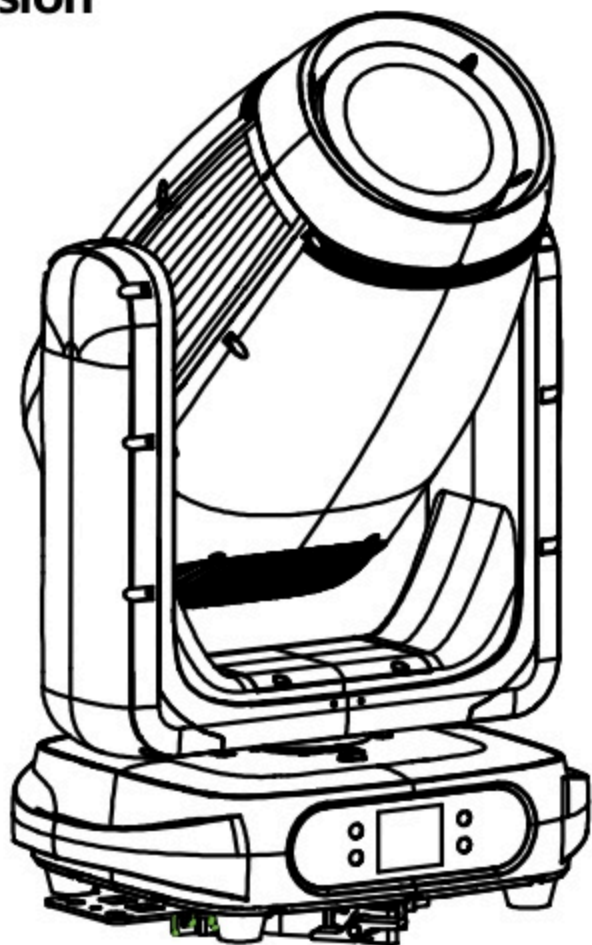

# Photometric

Beam Angle

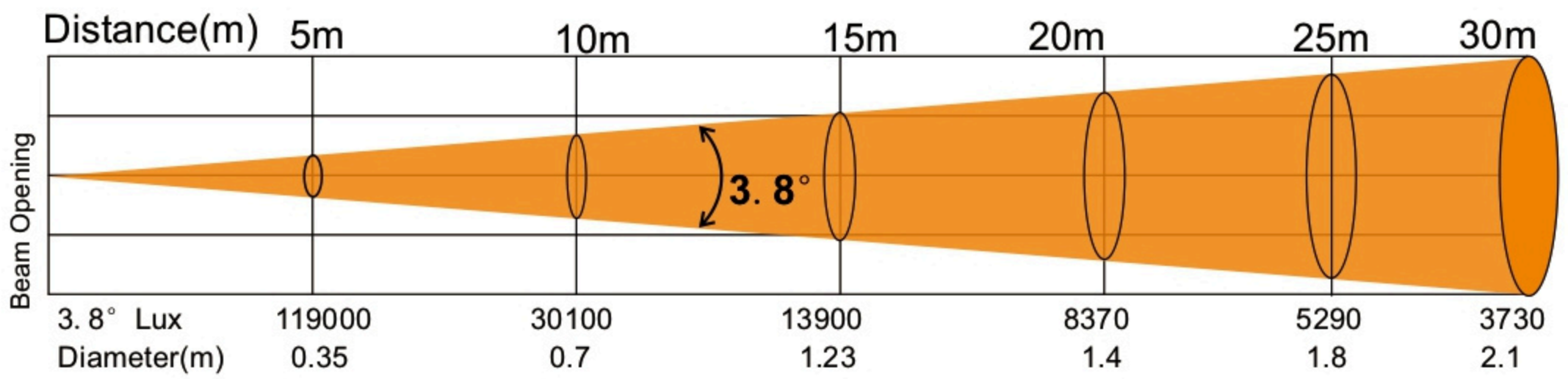

Beam Angle

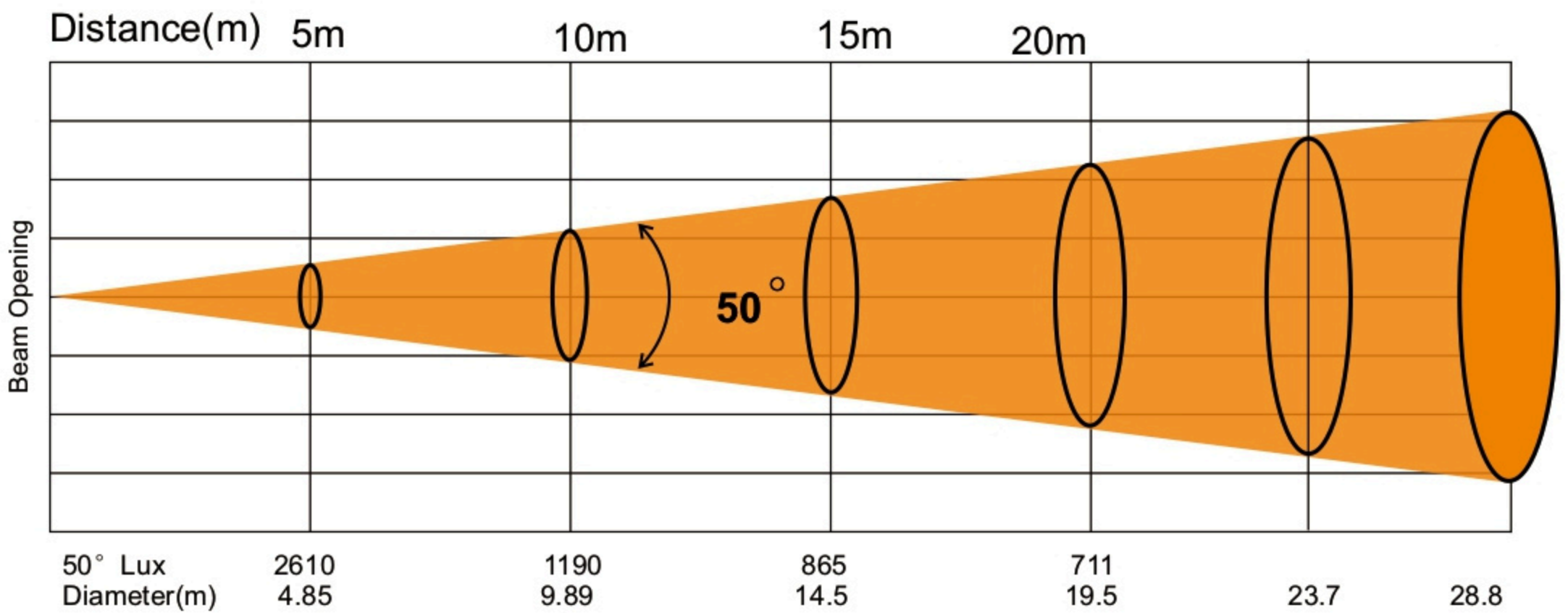

**Display:** To show the various menus and the selected function.

**Button:**

Enter	To perform the desired functions
DOWN	To go to move down in the menu
MENU	To enter into move backward or leave the menu
UP	To go backward or move up in the menu

ETHERNET: Transfers fixture' s information to a main controller.

DMX input: For DMX 512 operation, use 3/5-pin XLR plug cable to link the units together

DMX output: For DMX 512 operation, use 3/5-pin XLR plug cable to link the units together

## **How To Set The Unit**

### **Main Function**

Turn on the unit, press the MENU button into menu mode, and press the UP/DOWN button until the required function is shown on the monitor, select the function by the ENTER button, Use the UP/DOWN button to choose the SUB-Menu , press the ENTER button to store and automatically return to the last menu. Press the MENU button or let the unit idle one minute to exit menu mode.

The main functions are shown below:

MAIN MENU	SUBMENU	CHOICES 1	CHOICES 2	VALUES	
Set config	Address	001~512			
	Channel mode	Standard (36CH)			
		Basic (34CH)			
		Extended (56CH)			
	Mode	DMX			
		Slave			
		Auto	Auto Speed	0~255	
		Sound	Sensitivity	0~255	
	Fixture settings	No DMX	Blackout		
			Freeze		
		Pan Reverse	OFF		
			ON		
		Tilt Reverse	OFF		
			ON		
		Encoders	OFF		
			ON		
		Display Reverse	OFF		
			ON		
		Fan Set	Silent		
			Auto		
			High		
		Dimmer Curve	Square Law		
			Inv SQ Law		
			Linear		
			S Curve		
		Dimmer Mode	Standard		
			Stage		
			TV		
			Architecture		
			Theatre		
		Dimmer Frequen	800Hz		
			1200Hz		
3600Hz					
5000Hz					
10KHz					
15KHz					
20KHz					
Gobo Correction	25KHz				
	OFF				

			ON	
		Defaults	Factory Load	OFF
				ON
			User Load	OFF
				ON
			User save	OFF
				ON
		Language	English	
			Chinese	
		User Time	Password	*****
Time				
Information	Time Info	Current Time	***h	
		Total Run Time	***h	
		LED Run Time	***h	
	Temp Unit	Celsius		
		Fahrenheit		
	Error Info	No Error Record		
	Model Info			
Software Ver	V1.00			
Manual	Test	OFF		
		ON		
	Manual Control	Pan	0~255	
		Pan Fine	0~255	
		Tilt	0~255	
		Tile Fine	0~255	
		Pan/Tilt Speed	0~255	
		Strobe	0~255	
		Dimmer	0~255	
		Reserved	0~255	
		Reserved	0~255	
		Reserved	0~255	
		Zoom	0~255	
		Focus	0~255	
		Auto Focus	0~255	
		Auto Focus Fine	0~255	
		Color Wheel	0~255	
		Cyan	0~255	
		Magenta	0~255	
		Yellow	0~255	
CTO	0~255			

		Rot Gobo Wheel	0~255	
		Gobo Rot	0~255	
		Animation wheel	0~255	
		Iris	0~255	
		Prism	0~255	
		Prism Rot	0~255	
		Frost	0~255	
		Blade 1A	0~255	
		Blade 1B	0~255	
		Blade 2A	0~255	
		Blade 2B	0~255	
		Blade 3A	0~255	
		Blade 3B	0~255	
		Blade 4A	0~255	
		Blade 4B	0~255	
		AllBlade Rot	0~255	
		Reset	All	
			Pan&Tilt	
			Color	
			Gobo	
Other				
Calibrate	Password(008)	*** (008)		
		Pan	0~255	
		Tilt	0~255	
		Color Wheel	0~255	
		Cyan	0~255	
		Magenta	0~255	
		Yellow	0~255	
		Rot Gobo Wheel	0~255	
		Gobo Rot	0~255	
		Zoom	0~255	
		Focus	0~255	
		Iris	0~255	
		Prism	0~255	
		Prism Rot	0~255	
		Frost	0~255	
		Blade 1A	0~255	
		Blade 1B	0~255	
Blade 2A	0~255			
Blade 2B	0~255			

		Blade 3A	0~255
		Blade 3B	0~255
		Blade 4A	0~255
		Blade 4B	0~255
		AllBlade Rot	0~255

<b>CONTROL CHANNEL</b>			
CH	Standard (36CH)	Basic (34CH)	Extended (56CH)
1	Pan	Pan	Pan
2	Pan Fine	Tilt	Pan Fine
3	Tilt	Speed Pan/Tilt	Tilt
4	Tilt Fine	Shutter	Tilt Fine
5	Speed Pan/Tilt	Dimmer	Speed Pan/Tilt
6	Shutter	Reserved	Shutter
7	Dimmer	Reserved	Dimmer
8	Reserved	Reserved	Dimmer Fine
9	Reserved	Zoom	Reserved
10	Reserved	Focus	Reserved
11	Zoom	Auto Focus	Reserved
12	Focus	Auto Focus Fine	Zoom
13	Auto Focus	Color Wheel	Zoom Fine
14	Auto Focus Fine	Cyan Color	Focus
15	Color Wheel	Magenta Color	Focus Fine
16	Cyan Color	Yellow Color	Auto Focus
17	Magenta Color	CTO Color	Auto Focus Fine
18	Yellow Color	Rotating gobo	Color Wheel
19	CTO Color	Rotating gobo index	Color Wheel Fine
20	Rotating gobo	Animation wheel	Cyan Color
21	Rotating gobo index	Iris	Cyan Color Fine
22	Animation wheel	Prism	Magenta Color
23	Iris	Rotating prism	Magenta Color Fine
24	Prism	Frost	Yellow Color
25	Rotating prism	Blade 1A	Yellow Color Fine
26	Frost	Blade 1B	CTO Color
27	Blade 1A	Blade 2A	CTO Color Fine
28	Blade 1B	Blade 2B	Rotating gobo
29	Blade 2A	Blade 3A	Rotating gobo index
30	Blade 2B	Blade 3B	Rotating gobo index Fine
31	Blade 3A	Blade 4A	Animation wheel
32	Blade 3B	Blade 4B	Iris

33	Blade 4A	All Blade Rotation	Iris Fine
34	Blade 4B	Reset, LCD, Fans	Prism
35	All Blade Rotation		Rotating prism
36	Reset, LCD, Fans		Rotating prism Fine
37			Frost
38			Blade 1A
39			Blade 1A Fine
40			Blade 1B
41			Blade 1B Fine
42			Blade 2A
43			Blade 2A Fine
44			Blade 2B
45			Blade 2B Fine
46			Blade 3A
47			Blade 3A Fine
48			Blade 3B
49			Blade 3B Fine
50			Blade 4A
51			Blade 4A Fine
52			Blade 4B
53			Blade 4B Fine
54			All Blade Rotation
55			All Blade Rotation Fine
56			Reset, LCD, Fans

## DMX512 CONNECTION

Connect the DMX input (XLR connector) cable of the luminaire to the DMX output (female XLR connector) of your controller. You can connect multiple fixtures to this same DMX line in a daisy chain. The DMX cable must be a shielded twisted pair that is equipped with male and female XLR connectors.

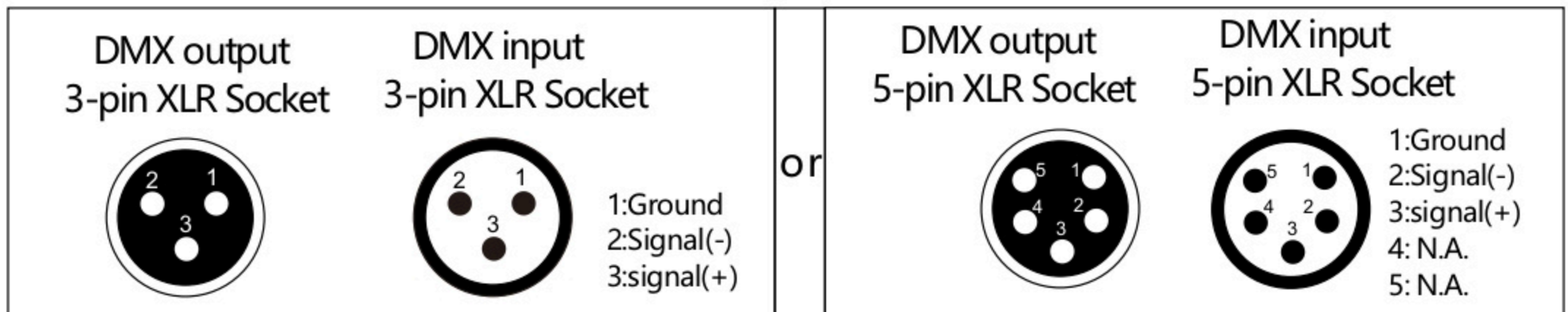

## USING DMX VIA ART-NET

To control the fixture via ArtNet, the fixtures must be interconnected with RJ45 cable. Be careful to set all necessary information regarding the ART-NET configuration with universe being used and specify in the menu that the fixture is being controlled through ART-NET (see OPTION DETAILS in the « OPTIONS » menu).

## THE 850W LED BSWF DMX ADDRESS SETTING

All 850W LED BSWF must have a DMX start address correctly set when using a DMX signal to control them. The DMX start address is the channel from which the 850W LED BSWF “listens” to the digital control information sent by the DMX controller.

The start address must conform to the one set on the DMX controller to control the fixture. This address is the DMX value that appears on the fixture’s display. You can set the same address for all the fixtures, or some of them, but you can also set a different address for each fixture, as needed. If you do set the same address for all the fixtures, they will all “listen” from the DMX channel you have set. The instructions sent by the DMX controller will affect all fixtures at the same time. If you set a different address per fixture, the DMX controller can control each independently. If, for instance, the fixtures are preset in 00-channel DMX mode (required for full control), you will need to adjust the DMX address for the luminaires as follows: The first unit with DMX address 001, the second with DMX address 037(36 + 1), the third with DMX address 073 (037+36), etc.



## DMX 512 Configuration







Please refer to below configurations to control the fixtures

Attentions:

1. The unit will maintain the last condition until reset if you cut-off the DMX signal.
2. For the channel Function, keep the value for about 5 seconds, then the corresponding function will take into effect.

Mode/Channel			Value	Function
St	Ba	Ex		
36CH	34CH	56CH		
1	1	1		<b>PAN Movement 8bit :</b>
			0-255	Pan Movement
2		2		<b>Pan Fine 16bit</b>
			0-255	Fine control of Pan movement
3	2	3		<b>TILT Movement 8bit :</b>
			0-255	Tilt Movement
4		4		<b>Tilt Fine 16bit</b>
			0-255	Fine control of Tilt movement
5	3	5		<b>Speed Pan/Tilt movement:</b>
			0-225	max to min speed
			226-235	blackout by movement
			236-245	blackout by all wheel changing
6	4	6	246-255	no function
				<b>Shutter, strobe:</b>
			00-10	Shutter closed
			11-20	No function (shutter open)
			21-117	Strobe effect slow to fast
			118-126	No function (shutter open)
			127-180	Pulse-effect in sequences
			181-191	No function (shutter open)
192-245	Random strobe effect slow to fast			
7	5	7		<b>Dimmer intensity:</b>
			0-255	Intensity 0 to 100%
		8		<b>Fine Dimmer intensity:</b>
			0-255	Dimmer intensity fine
8	6	9		Reserved
9	7	10		Reserved
10	8	11		Reserved
11	9	12		<b>Zoom :</b>
			0-255	Zoom adjustment from small to big
		13		<b>Zoom Fine:</b>
			0-255	Zoom adjustment Fine
12	10	14		<b>Focus :</b>

			0-255	Continuous adjustment from near to far
		15		<b><u>Focus Fine:</u></b>
			0-255	Continuous adjustment Fine
13	11	16		<b><u>Auto Focus :</u></b>
			0-50	Auto Focus Off
			51-100	5m
			101-150	7.5m
			151-200	10m
			201-255	15m
14	12	17		<b><u>AutoFocus Fine:</u></b>
			0-255	Continuous adjustment Fine
15	13	18		<b><u>Color Wheel:</u></b>
			00-3	Open / white
			4-7	Color 1(CTB) 
			8-11	Color 2(Magenta) 
			12-15	Color 3(Congo Blue) 
			16-19	Color 4(Green) 
			20-23	Color 5(Orange) 
			24-27	Color 6(Light Blue) 
			28-31	Color 7(Red) 
			32-127	Color indexing
			128-189	Forwards rainbow effect from fast to slow
			190-193	No rotation
			194-255	Backwards rainbow effect from slow to fast
			0-255	Color Wheel colour change to any position Fine
16	14	20		<b><u>Cyan Color :</u></b>
			0-255	Cyan (0-white, 255-100% Cyan)
		21		<b><u>Cyan Color Fine :</u></b>
			0-255	Cyan Fine
17	15	22		<b><u>Magenta Color :</u></b>
			0-255	Magenta (0-white, 255-100% magenta)
		23		<b><u>Magenta Color Fine :</u></b>
			0-255	Magenta Fine
18	16	24		<b><u>Yellow Color :</u></b>

			0-255	Yellow (0-white, 255-100% Yellow)	
		25		<b><u>Yellow Color Fine :</u></b>	
			0-255	Yellow Fine	
19	17	26		<b><u>CTO Color :</u></b>	
			0-255	CTO (0-white, 255-100% CTO)	
		27		<b><u>CTO Color Fine :</u></b>	
			0-255	CTO Fine	
				<b><u>Rotating gobos, cont. rotation 1:</u></b>	
			00-9	Open	
			10-19	Rot. gobo 1	
			20-29	Rot. gobo 2	
			30-39	Rot. gobo 3	
			40-49	Rot. gobo 4	
			50-59	Rot. gobo 5	
			60-69	Rot. gobo 6	
			70-77	Rot. Gobo 7	
			78-93	Gobo 1 shake slow to fast	
			94-109	Gobo 2 shake slow to fast	
			110-125	Gobo 3 shake slow to fast	
			126-141	Gobo 4 shake slow to fast	
			142-157	Gobo 5 shake slow to fast	
			158-173	Gobo 6 shake slow to fast	
			174-189	Gobo 7 shake slow to fast	
			190-221	Gobo wheel rotation forwards from fast to slow	
			222-223	No rotation	
			224-255	Gobo wheel rotation f backwards from slow to fast	
				<b><u>Rotating gobo index,rotating gobo rotation 1:</u></b>	
			0-127	Gobo indexing	
			128-189	Forwards gobo rotation from fast to slow	
			190-193	No rotation	
			194-255	Backwards gobo rotation from slow to fast	
		30		<b><u>Rotating gobo indexing Fine 1:</u></b>	
			0-255	Fine indexing	
22	20	31		<b><u>Animation wheel:</u></b>	

			0-7	open
			8-127	Forwards rotation from fast to slow
			128-135	No rotation
			136-255	Backwards rotation from slow to fast
23	21	32		<b><u>Iris:</u></b>
			0-191	Max. diameter to Min.diameter
			192-223	Pulse closing fast to slow
			224-255	Pulse opening slow to fast
		33		<b><u>Iris Fine:</u></b>
			0-255	Iris Fine
24	22	34		<b><u>Prism:</u></b>
			0-127	Open
			128-255	5-Facet Prism
25	23	35		<b><u>Rotating prism index, rotating prism rotation</u></b>
			0-127	Prism indexing
			128-189	Forwards prism rotation from fast to slow
			190-193	No rotation
			194-255	Backwards prism rotation from slow to fast
		36		<b><u>Rotating prism indexing Fine :</u></b>
			0-255	Fine indexing
26	24	37		<b><u>Frost:</u></b>
			0-255	0-100% Frost
27	25	38		<b><u>Blade 1A :</u></b>
			0-255	Open to Close
		39		<b><u>Blade 1A Fine :</u></b>
			0-255	Open to Close Fine
28	26	40		<b><u>Blade 1B :</u></b>
			0-255	Open to Close
		41		<b><u>Blade 1B Fine :</u></b>
			0-255	Open to Close Fine
29	27	42		<b><u>Blade 2A :</u></b>
			0-255	Open to Close
		43		<b><u>Blade 2A Fine :</u></b>
			0-255	Open to Close Fine
30	28	44		<b><u>Blade 2B :</u></b>
			0-255	Open to Close
		45		<b><u>Blade 2B Fine :</u></b>
			0-255	Open to Close Fine

31	29	46		<b><u>Blade 3A:</u></b>
			0-255	Open to Close
		47		<b><u>Blade 3A Fine :</u></b>
			0-255	Open to Close Fine
32	30	48		<b><u>Blade 3B :</u></b>
			0-255	Open to Close
		49		<b><u>Blade 3B Fine :</u></b>
			0-255	Open to Close Fine
33	31	50		<b><u>Blade 4A :</u></b>
			0-255	Open to Close
		51		<b><u>Blade 4A Fine :</u></b>
			0-255	Open to Close Fine
34	32	52		<b><u>Blade 4B :</u></b>
			0-255	Open to Close
		53		<b><u>Blade 4B Fine :</u></b>
			0-255	Open to Close Fine
35	33	54		<b><u>All Blade Rotation :</u></b>
			0-255	All Blade Rotation
		55		<b><u>All Blade Rotation Fine :</u></b>
			0-255	All Blade Rotation Fine
36	34	56		<b><u>Control, reset, internal programs:</u></b>
			00-4	unused
			5-9	Display Off
			10-14	Display On
			15-19	Display Invert Off
			20-24	Display Invert On
			25-26	Auto fan control mode
			27-28	Stage fan control mode
			29-30	Silence fan control mode
			31-32	Super Silence fan control mode
			33-34	Constant Fans Off
			35-36	Constant Fans On
			37-44	unused
			45-49	Square Law
			50-54	Linear
			55-58	1.2K
59-62	2.4K			
63-66	16K			
67-69	25K			

			70-74	Gobo correction Off
			75-79	Gobo correction On
			80-84	All motor reset
			85-87	Scan motor reset
			88-90	Colors motor reset
			91-93	Gobo motor reset
			94-96	unused
			97-99	Other motor reset
			100-119	unused
			120-139	unused
			140-159	unused
			160-179	unused
			180-199	unused
			200-219	unused
			220-239	unused
			240-255	unused

## **ERROR MESSAGES**

When you turn on the 350W LED hybrid fixture, it will first perform an automatic reset. The display may show "Err channel is XX" indicating there is a problem with one or more of the channels.

"XX" represents channel 1, 2, 3, 4, 5 or 6, which contain the testing sensor for positioning. For example, the message, "Err channel is Pan movement" , indicates an error in channel 1. If there is an error on channel 1 and channel 3 at the same time, the following error message may appear:

"Err channel is Pan movement" , "Err channel is Tilt movement" . The system will flash twice, and the fixture will generate a second reset. If the error message persists after more than two resets, the channels showing errors will not work properly but the other channels will function normally.

Please contact your authorized dealer or manufacturer for service and do not attempt to repair the luminaire yourself.

### **PAN- movement Er**

(PAN-yoke movement error): This message will appear after the reset if the yoke' s magnetic-indexing circuit malfunctions (failed sensor or magnet missing) or the stepping-motor is defective (also caused by its driving IC on the main PCB). The PAN- movement does not return to the default position after the reset.

### **TILT- movement Er**

(TILT- head movement error) This message will appear after the reset of the fixture if the head' s magnetic-indexing circuit malfunctions ((Optical Sensor or Magnetic Sensor fails)) or the stepper motor is defective (or its driving IC on the main PCB).The TILT-movement is not located in the default position after the reset.

### **Zoom Er**

(Zoom error) This message will appear after the reset of the fixture if the head' s magnetic-indexing circuit malfunctions (Optical Sensor or Magnetic Sensor fails) or the stepper motor is defective (or its driving IC on the main PCB). . The Zoom -movement is not located in the default position after the reset.

### **Focus Er**

(Focuswheel error) This message will appear after the reset of the fixture if the head' s magnetic-indexing circuit malfunctions (Optical Sensor or Magnetic Sensor fails) or the stepper motor is defective (or its driving IC on the main PCB).The Focus -movement is not located in the default position after the reset.

### **Color wheel Er**

(Color wheel- error) This message will appear after the reset of the fixture if the head' s magnetic-indexing circuit malfunctions (sensor failed or magnet missing) or the stepper motor is defective (or its driving IC on the main PCB).The Color - movement is not located in the default position after the reset.

**Rot\_Gobo wheel Er**

(Rot\_Gobo1wheel - error) This message will appear after the reset of the fixture if the head's magnetic-indexing circuit malfunctions (sensor failed or magnet missing) or the stepper motor is defective (or its driving IC on the main PCB). The Rot\_Gobo1 - movement is not located in the default position after the reset.

**Fix\_Gobo wheel Er**

(Fix\_Gobowheel - error) This message will appear after the reset of the fixture if the head's magnetic-indexing circuit malfunctions (sensor failed or magnet missing) or the stepper motor is defective (or its driving IC on the main PCB). The Fix\_Gobo - movement is not located in the default position after the reset.

**Prism Er**

(Prism error) This message will appear after the reset of the fixture if the head's magnetic-indexing circuit malfunctions (sensor failed or magnet missing) or the stepper motor is defective (or its driving IC on the main PCB). The Prism\_5 - movement is not located in the default position after the reset.

**Frost Er**

(Frost - error) This message will appear after the reset of the fixture if the head's magnetic-indexing circuit malfunctions (sensor failed or magnet missing) or the stepper motor is defective (or its driving IC on the main PCB). The Frost 1 - movement is not located in the default position after the reset.

## **CLEANING AND MAINTENANCE**

The following points have to be considered during inspection:

- 1) All screws for installing the devices or parts of the device have to be tightly connected and must not be corroded.
  - 2) There must not be any deformations to the housing , lenses, rigging and installation points (ceiling, suspension, trussing).
  - 3) Motorized parts must not show any signs of wear and must move smoothly without issue.
  - 4) The power supply cables must not show any damage, material fatigue or sediment.
- Further instructions depending on the installation location and usage have to be adhered to by a qualified installer and any safety concerns have to be removed.



# Contact Us

---



SALES@ILLUSIONUNIVERSE.CA



UNIT 11, 10 FALCONER DRIVE,  
MISSISSAUGA , ONTARIO, CANADA



WWW.ILLUSIONUNIVERSE.CA